

Witnesses:
Herbert E. Metcalf
Francis W. Test
Henry H. Johnson

FIG. 38.

Inventors:
Enrico Fermi
Leo Szilard

By: *Robert A. Saunders*
 Attorney.

Inside the atomic patent office

Before Stagg Field, before Trinity, before the atomic age dawned above Hiroshima and Nagasaki, nascent nuclear technologies emerged into a world unsure of how to manage the bevy of new and dangerous secrets. The surprising method of early atomic control? Patent censorship.

BY ALEX WELLERSTEIN

WOULD BE SWORN TO SECRECY,” William Shurcliff wrote to himself in a May 14, 1942 memo. Earlier that day he had met with the prominent scientist-administrator Vannevar Bush, head of the Office of Scientific Research and Development (OSRD), and Conway Coe, Commissioner of Patents.¹ They had recruited Shurcliff for a job that would be not just new to him, but new to the world, putting him at the center of a Manhattan Project department at the leading edge of atomic control—a department that would later be almost completely lost to history—the atomic patenting program. Shurcliff would become, essentially, the censor of atomic patents.

William Asahel Shurcliff was a Harvard man, graduating with an undergraduate degree *cum laude* in 1930, a PhD in physics in 1934, and a degree in business

Two years after the first self-sustaining chain reaction, and nearly a year before the atomic bombings of Japan, Enrico Fermi and Leo Szilard filed this patent for a “neutronic reactor.” They waited more than 10 years before the patent was granted.

administration in 1935. Before the United States entered World War II, Shurcliff worked as head of the spectrophotometric laboratory at the American Cyanamid Company’s Calco Chemical Division, where he had been responsible for maintaining Calco’s patent records and had in fact filed for several patents himself. In early 1942, a friend inside the OSRD suggested he join its staff, and Shurcliff, having feared the draft, leapt at the opportunity. His first few months at the OSRD were spent as a senior technical aide in the Liaison Office, helping direct top-secret technical intelligence about the Axis enemies to the relevant research divisions. Vannevar Bush worked directly across the hall, and when he needed to find an atomic patent censor—a secret job that involved a comprehensive look at the atomic energy project, in contrast to the compartmentalization usually undertaken for security purposes—he turned to Shurcliff.²

During their May 1942 meeting, Bush and Coe told Shurcliff the bare bones of the problem. The military had a top-secret program to develop a new weapon,

the atomic bomb, based on discoveries openly published a few years earlier (nuclear fission and the possibility of the nuclear chain reaction). Bush was afraid that private inventors would intuit the use of atomic energy and file patent applications, thereby staking a legal claim to such inventions—and endangering the security of the U.S. atomic program.

Bush’s concern was not baseless; it had come to the fore after he learned that French émigré physicists on Frédéric Joliot-Curie’s Collège de France team were attempting to file nuclear reactor-related patent applications in multiple countries and were trying to cut a deal with Britain for the assurance of France’s post-war nuclear position in exchange for the patent rights.³

Contesting the scientists’ patent applications, Bush understood, would risk a security leak—it would reveal that the United States had its own nuclear designs, its own reactor research, and its own bomb program. To allow them to be processed normally, however, would be perhaps even worse: It would put the U.S. nuclear program in an unfavorable legal situation, potentially making it deferent to French scientists (who had, in the case of Joliot-Curie, increasingly Marxist leanings). The answer, Coe had suggested to Bush, was to control the technology by declaring the patent applications “secret.”⁴ This was possible thanks to Public Law No. 700, legislation rooted in World War I and revised before U.S. entry into World War II that gave the patent commissioner the authority to declare applications secret during both peace and wartime.⁵ Once declared secret, these applications would sit, unprocessed, in a Patent Office vault; only after the secrecy order was lifted would they be subjected to the eyes of a patent examiner, who would parse out any questions of priority and interference and decide whether patents ought to be granted.⁶

Bush worried that “the French problem,” as he and Coe called it, was not unique and that others would file patent applications that overlapped with secret U.S. government work. The Patent Office monitored militarily relevant applications, but it had neither enough knowledge about the evolving bomb project nor

the technical expertise to identify potentially problematic applications. As Bush told Coe in April 1942, it was important that any patent applications “which have any significance” to the nascent bomb “be withheld from issue.”⁷ To avoid accusations that the government was conspiring against private inventors for its own benefit, Bush wanted the person making such decisions to be separate from the actual development of the bomb. What they needed, Bush explained to Coe, was someone within the OSRD but not yet within the bomb project, someone who could be expected to quickly obtain technical competence in all aspects of the atomic energy program, someone who already knew his way around patent issues. As far as Bush was concerned, the man for the job was right across the hall: Shurcliff.⁸

And so in May 1942, Bush and Coe briefed Shurcliff on his first assignment as atomic patent censor. He would act as liaison between the Patent Office and the OSRD’s secret S-1 Uranium Committee, advising officials in the Patent Office “as to subjects (S-1) or fields in which there was the possibility of desiring secrecy orders.” Loftier possibilities were also being discussed, as evidenced by the last line of Shurcliff’s May 1942 memo to himself: “Taking over of [private inventors’] patents or patent applications by

the highest priority, soon to be run by the army as the Manhattan Project. Shurcliff visited the University of Chicago’s Metallurgical Laboratory, where scientists were building the first nuclear reactor (Leo Szilard was “short, fat,” he noted to himself); he browsed relevant reports in the library of the National Bureau of Standards in Washington, D.C.; he visited the St. Louis site where foreign uranium ores were milled into black oxides.¹⁰

And he began to review patent applications.

By July 1, Shurcliff told Bush that he had found around 35 applications that required secrecy orders. He was keeping careful records, utilizing a system of six separate card indices to keep track of patents, inventors, and subjects. He made sweeps of patent application titles under relevant patent subject headings and focused on identifying inventors whose work he felt was particularly likely to be germane to S-1 work. Culling names from S-1 reports, from articles published in the three preceding years in *Physical Review*, *Review of Modern Physics*, and *Scientific Abstracts*, and from the roster of scientific personnel of the National Academy of Sciences, Shurcliff compiled a list of 600 scientists from whom a patent application would trigger an immediate red flag. By March 1943, the list had grown to

as William Shockley and Robert Van De Graaff, both of whom had patent applications that attracted Shurcliff’s attention. Many others, however, were unaffiliated with the government, and of these, many were not even in the United States (such as the members of the Collège de France team).¹¹ Though initially Shurcliff focused on physicists—no doubt due to his own training—he eventually enlarged his scope to cover other disciplines, such as chemistry, metallurgy, and engineering.

What had begun as a “survey of the art” became a full program to “locate, examine, and make secret all non-gov’t-controlled U.S. patent applications related to S-1,” as Shurcliff put it.¹² He requested patent applications from the Patent Office and from S-1 contractors whenever applications were filed on behalf of their personnel, penciling in the titles and inventors in his notebooks and then labeling each one “secrecy recommended” or “secrecy not recommended.” As he later recalled in an unpublished autobiographical manuscript, if the application was “hot”—that is, if it “had, or might have, an atomic-bomb connection”—he would have it “put to sleep” by sending a letter to the chief OSRD patent officer, navy lawyer Capt. Robert A. Lavender, and would indicate whether the government should think about trying to acquire the patent from the inventor.¹³ (At first, Shurcliff ran into difficulty getting the patent applications on a timely basis from the Patent Office, but after an application that he had requested was instead not only granted by the office but also mentioned in a front-page *New York Times* article, his troubles with this were alleviated.)¹⁴ The patents that Shurcliff directed be put to sleep ranged from those obviously connected with nuclear technology, such as speculations on reactor designs, to others whose nuclear connection was less obvious, including technologies potentially relevant to isotopic separation, such as those in the fields of mass spectrometry (similar to the electromagnetic method of enrichment) and centrifuge development.

Shurcliff tried to be a conscientious censor, limiting his secrecy orders to those cases he felt absolutely called for it and periodically rescinding his orders if he changed his mind about the importance of

Contesting the scientists’ patent applications, Bush understood, would risk a security leak—it would reveal that the United States had its own nuclear designs, its own reactor research, and its own bomb program. To allow them to be processed normally, however, would be perhaps even worse.

the gov’t is not *now* in view. An act of Congress might be required.”⁹

Shurcliff began with a whirlwind tour of the S-1 project facilities. The bomb project was, in mid-1942, transforming from a primarily investigatory, exploratory endeavor into a crash development program of

many more than 1,000 names. Included were scientists involved with the OSRD atomic endeavor—Szilard, Enrico Fermi, Ernest O. Lawrence, Emilio Segrè, and Harold Urey, to cite some of the most recognizable—as well as those working on non-S-1-related wartime research, such

an invention. In March 1943, for example, he repealed his secrecy order on some applications related to mass spectrometry that he had decided “should be allowed to mature in the normal and unrestricted manner,” explaining that in the months since he had declared them secret his interest in them had “appreciably decreased.” He had begun to fear, he explained to Captain Lavender, that “the damage done to industry by maintaining the secrecy orders must be increasing, especially in the petroleum industry and in the field of organic chemistry generally, all as attested by recent petitions filed by the individuals or assignees concerned with the [spectrometry] cases listed above.”¹⁵

Industrial contractors who had orders of patent secrecy leveled against them, such as Westinghouse Electric and Standard Oil Development Co., occasionally protested; sometimes Shurcliff recommended rescinding the orders, sometimes he denied the petitions flat out. Most of the industrial contractors understood that the orders were related to the OSRD’s secret wartime work; their petitions were primarily motivated because they wanted to file the applications abroad or because they believed the patent would give them an edge in their field.

But for private inventors, a secrecy order could be frustrating. In a typical experience, an inventor whose patent application was deemed sensitive would receive a mysterious notice sent from the Patent Office (not the OSRD) under the bold heading of “SECRECY ORDER.” The letter cursorily explained patent secrecy laws, informed the inventor that the patent had been declared secret, and said there would be penalties if the patent’s contents were made public, but gave no explanation as to why the application had been deemed secret.¹⁶

One private inventor was actually encouraged by the order of secrecy he

received against one of his applications. To Sol Wiczer, it meant that the government might be interested in his invention or that the invention was important. On May 14, 1944, he phoned Shurcliff at his office to ask about the secrecy order and offer his services to the government.¹⁷

did practically all patents related to isotope separation because of its importance to uranium enrichment.¹⁸ In a memo to Carroll L. Wilson, Bush’s executive assistant, about the “slightly suspicious incident” of Wiczer’s phone call, Shurcliff wrote that the patent was only “moderately pertinent” to S-1 work and that his application indicated that Wiczer was working solo, unaffiliated with a lab or government agency.¹⁹

The very same day that Wiczer telephoned Shurcliff, another distressing possibility arose. David Z. Beckler, Shurcliff’s assistant and eventual heir to the patent censoring job (who would later become the executive officer of Dwight Eisenhower’s President’s Science Advisory Committee), suggested that “enemy agents might file ‘paper’ applications on [S-1-related subjects] to obtain leads as to U.S. secrecy policy and perhaps additional information.”²⁰ The idea was that an enemy might probe the status of the U.S. bomb program by filing applications on the subject and seeing if they were censored. Shurcliff felt that Beckler’s concerns were worth considering. In the same memo addressing the Wiczer affair, he suggested to his superiors that from his lists he “could supply names” of inventors who had no known institutional affiliations, and that

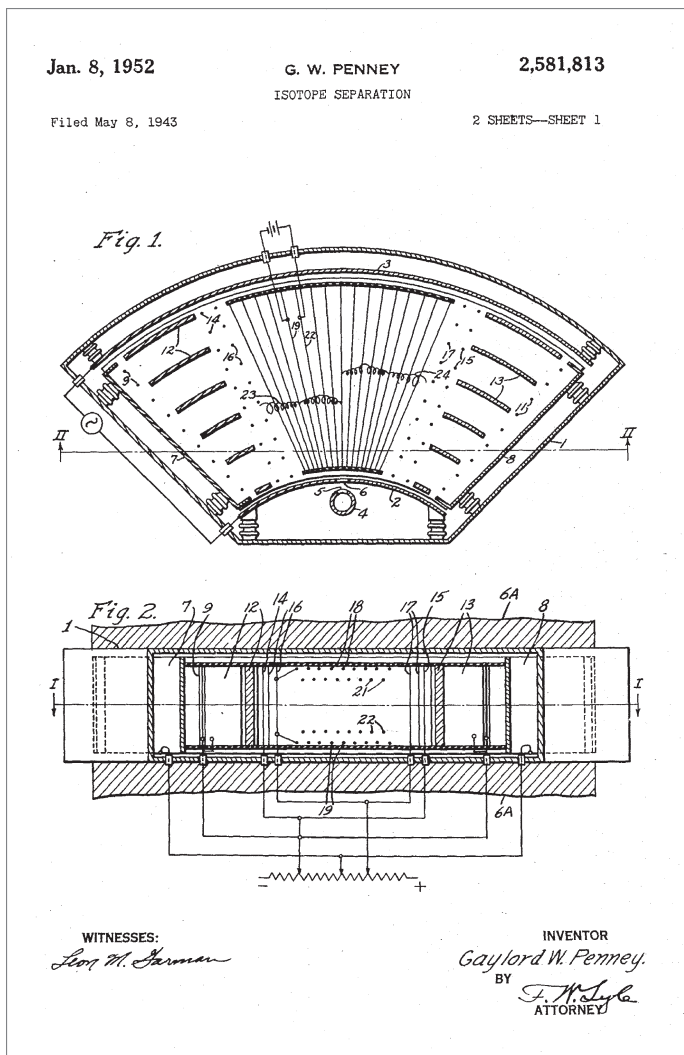

Shurcliff “put to sleep” this patent for an isotope separation method.

Alarmed, Shurcliff told him, in true bureaucratic fashion, to put the question in writing. He needed to buy some time while he tried to figure out what had gone wrong: How did this uncleared, unknown inventor not only discover that the OSRD had issued the secrecy order, but that Shurcliff himself, the atomic censor, had issued it?

Wiczer had filed a patent on isotopic separation in November 1942. Shurcliff felt the application was “vague” but required a secrecy order nonetheless—as

based on these, they “may wish to recommend to proper authorities that FBI or other investigations be made of the 10 or 20 ‘lone wolf’ inventors who have filed applications in the ‘S-1’ field.”²¹ The “lone inventor,” that much cherished trope in U.S. patent law, a stock character in an Edisonian model brought out to justify the need for patent protection, had, in the eyes of Manhattan Project security, become the “lone wolf,” a vicious spy seeking to crack the atomic project by means of patent applications.

Shurcliff's memo was forwarded to Lt. Col. John Lansdale Jr., head of Manhattan Project security, who promised to look into the Wiczer situation and expressed eager interest in the list of the "lone wolves" and anything providing "factual basis for suspicion of a fishing expedition."²² A special agent made two investigations into Wiczer's past, examining his work and education records and interviewing an employer, and determined what had happened. Wiczer, it turned out, was a former patent examiner, and he likely still had contacts within the Patent Office who could have discovered that it was Shurcliff who had censored his application. Wiczer was dismissed as a threat, and Lansdale's query into other unaffiliated scientists seems to have come to nothing.

Shurcliff continued as the atomic patent censor through October 1944, when he was transferred to another project within the OSRD. In early 1945 he became the assistant of Henry DeWolf Smyth, eventually helping to edit the famous "Smyth Report," the first official declassified account of the wartime atomic project, and later become the technical historian of the Operation Crossroads nuclear tests, among other accomplishments.²³ As the Manhattan Project's patent censor, Shurcliff had "put to sleep" at least 131 patent applications from at least

had a massive patenting program initiated by Bush, sanctioned by President Franklin Roosevelt, and headed by Lavender that sought to obtain complete governmental control over the field of atomic energy—including weaponry—by means of patents. Over the course of this program—almost totally ignored by historians of the Manhattan Project—more than 8,500 technical reports were examined by patent officers, more than 6,300 technical notebooks were scrutinized, and 5,600 different inventions in 493 different categories covering everything "from the raw ore as mined to the atomic bomb" were docketed by Lavender's office. The result? Close to 2,100 separate patent applications approved for filing *in secret* by 1947, when the Manhattan Project's authority was transferred to the Atomic Energy Commission (AEC).²⁵

One might wonder why they sought to control the spread of technology through patents. The notion seems misplaced to the modern mind: Would the United States really have forfeited its atomic monopoly on account of something as legalistic as a patent claim? Would it have sued Russia for infringement after its first bomb detonation?

But patent control made more sense in the early 1940s than it does today. When the Manhattan Project was young, the

pushing into unknown territory, and it was unclear what new laws, institutions, and politics would develop around the atomic bomb. That it would be a weapon of great power was obvious to all who knew about it, but what kind of political and legal control framework would be required was still up for grabs.

Seen through the eyes of an OSRD administrator in mid-1942, patents make more sense: How does one control technology? That patents played a role in the answer to that question for Bush, Groves, and Shurcliff makes more sense in light of their backgrounds. All had scientific or engineering educations, and Bush and Shurcliff had extensive experience with patents as a method of controlling technology for the purposes of industry.

Patents filled what Manhattan Project administrators thought was a hole in their system of long-term control over the bomb. What if Congress had *not* created an organization like the AEC, which was given unprecedented power to declare ownership not only over the *materials* of atomic energy, but also the *ideas*? *Who would own the bomb?*

If the question seems specious, one need simply look to the so-called French problem, in which the issue of ownership of atomic ideas intersected with questions of international diplomacy and post-war atomic arrangements. There were other problems as well: What about scientists *within* the project who asserted ownership over their own work? Bush had attempted to head this off early on, in 1942, when he made sure that all OSRD contracts relating to atomic energy gave the government the ability to own all patents produced by the project if it so wanted to.²⁶ Unfortunately for Bush, there were scientists who had made key discoveries *before* being under an OSRD contract.

Szilard, for example, tried to hold onto his patent rights for his work on the first nuclear reactor in order to gain more say in the project; he was eventually given the choice between leaving the project or handing over his patents, and he chose the latter.²⁷ The patents covering the fundamental chemistry of plutonium were the subject of a dispute lasting more than a decade between the inventors (Segrè, Glenn T. Seaborg, Arthur Wahl, and Joseph

What if Congress had not created an organization like the AEC, which was given unprecedented power to declare ownership not only over the materials of atomic energy, but also the ideas? *Who would own the bomb?*

95 inventors; in economic terms, this was a significant, unprecedented number, given that entire industries can rise and fall on a handful of patent claims.²⁴

Censoring atomic patents was not the OSRD or Manhattan Project's only foray into patent territory; in fact, the project

idea that the United States would eventually erect a massive, secretive civilian organization—the AEC—to manage its atomic affairs was far from self-evident. Bush and Gen. Leslie R. Groves, the army engineer in charge of the bomb project, knew that they were in many ways

Kennedy), their host institution (University of California, Berkeley), and the government. In that case, the incentive was more economic than political: The inventors, the university, and the government all realized that the royalties would tabulate in the millions over time. In the end, the AEC awarded each of the inventors \$100,000 in 1955, far less than they were worth, but still a substantial sum at the time.²⁸ The idea of private individuals using privately held atomic patents as a way of inhibiting or influencing the government was perceived as a very real threat during the war years, one reinforced by occasional attempts by individuals to do just that.

From the point of view of project administrators, patents ensured the government's legal ownership of the bomb with pre-existing means—that is, without resorting to or relying on extraordinary legislation or special exceptions. It was a policy that they thought would stand up to the glare of post-war scrutiny no matter what choices Congress made about the governance of the atom because it was all done within the confines of existing laws. The fear that extralegal activities during wartime could lead to post-war repercussions was born out of experience: Before he took over the Manhattan Project patent program, Lavender had spent years negotiating settlements for the navy for British patents violated by the United States during World War I.²⁹ While today one might presume that responsibility for the bomb gave officials a blank check for authority and power, there were some issues—especially when large sums of money were potentially at stake—upon which they trod carefully and tried to play by the book, patents being one such issue.³⁰

It is easy, from a twenty-first-century perspective, to dismiss patents as a method for atomic control—we know that

secrecy was extended far longer than project administrators thought it would be, that the U.S. monopoly on the bomb was short-lived, that the path toward international control of atomic weapons has been long and imperfect. Patents rapidly fell out of the atomic-control equation after the war, when it became clear that the atomic bomb would warrant “special” consideration in the form of new institutions

accomplished? “If the United States has a strong patent position, the achievement of the above will be facilitated,” Groves wrote. The patent program would, he explained, “lay the groundwork for proper control thereafter.”³²

For his part, Vannevar Bush, usually remembered for championing scientists' ability to patent their inventions, remarked years later that it was “paradoxical that I, who am a great believer in the [patent] system, should have been called upon to commit this particular sin,” the seizing of patent rights by the government. “In the process I personally destroyed more property in the form of patents than any other man living.”³³

Were patents so ill suited for controlling secret nuclear technology? If one eliminates the openness normally associated with patents, as the censoring program did, then they simply become legal monopolies over technology. Secrecy orders served as a way to put a short-term kibosh on nongovernmental nuclear work without arousing too much suspicion or utilizing any extralegal mechanisms. Today the development of nuclear weapons is closely associated with

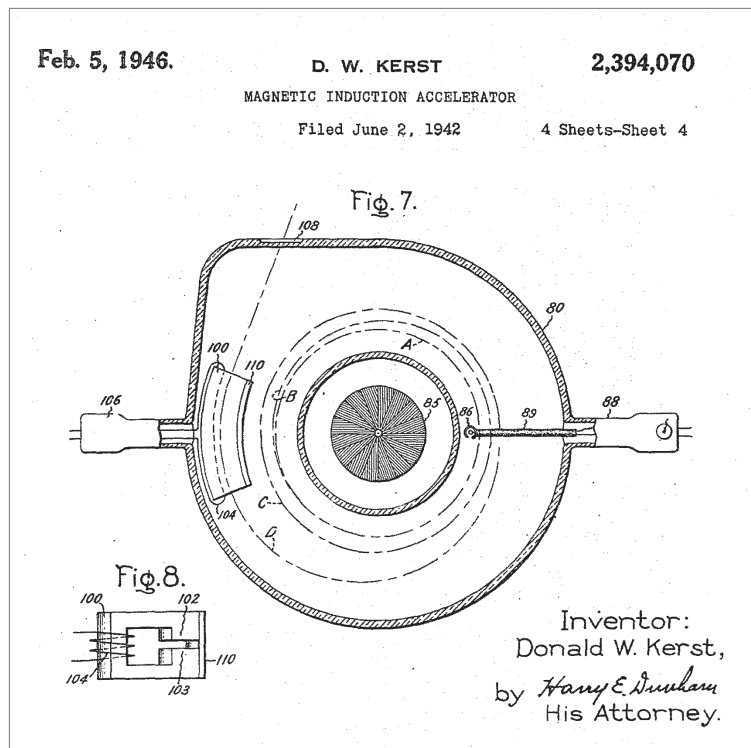

This once-secret patent was thought to be relevant to the construction of a calutron.

and laws and that Congress and the courts would allow the government to take special liberties in controlling it.³¹

But it is clear that during the war, patents were seen as a vital part of the plans for both wartime and post-war control of atomic energy. In August 1943, Groves reported to the vice president, secretary of war, and the army chief of staff that, “If the possibility of world disaster through the development of this super explosive and its possible military by-products is to be avoided and the enormous hazard involved in preparation minimized, the utilization of atomic power must always be under close control of governments interested in the welfare of mankind rather than in absolute domination and exploitation of other peoples.” How would this be

secret, expansive government control, and heightened obsession with “national security.” But the story of the Manhattan Project patent program is a reminder that in the early days of the atomic age, not even those who participated in the bomb program knew how best to handle atomic knowledge. The answer to the question of whether such knowledge could be controlled within an existing structure of U.S. governance, like the Patent Office, or would require something more, is today so clear that it can be difficult to remember that it was ever asked at all. ■

FOR NOTES, PLEASE SEE P. 60.

Alex Wellerstein is a PhD candidate in Harvard University's Department of the History of Science. This article is based on a longer paper published in the March 2008 issue of *Isis*.

Intergovernmental Panel on Climate Change.

2. See H. J. Schellnhuber, W. Cramer, N. Nakicenovic, T. M. L. Wigley, and G. Yohe, eds., *Avoiding Dangerous Climate Change* (Cambridge: Cambridge University Press, 2006).

3. Timothy M. Lenton, Hermann Held, Elmar Kriegler, Jim W. Hall, Wolfgang Lucht, Stefan Rahmstorf, Hans Joachim Schellnhuber, "Tipping Elements in the Earth's Climate System," *Proceedings of the National Academy of Sciences*, vol. 105, no. 6, pp. 1786–93 (2008).

4. R. Schubert et al., *Climate Change as a Security Risk* (Berlin: German Advisory Council on Global Change WBGU, 2007).

5. David D. Zhang, Peter Brecke, Harry F. Lee, Yuan-Qing He, Jane Zhang, "Global Climate Change, War, and Population Decline in Recent Human History," *Proceedings of the National Academy of Sciences*, vol. 104, 19, 214–19.

6. Schubert et al., *Climate Change as a Security Risk*.

7. U.N. Development Program, "Fighting Climate Change: Human Solidarity in a Divided World," 2007.

8. Commission on Human Security, "Human Security Now," 2003.

9. Daniel Deudney, "Environment and Security: Muddled Thinking," *Bulletin of the Atomic Scientists*, May/June 1991, pp. 23–28; Lothar Brock, "The Environment and Security: Conceptual and Theoretical Issues," in Nils Petter Gleditsch, ed., *Conflict and the Environment* (Dordrecht, The Netherlands: Kluwer Academic Publishers, 1997).

10. Thomas Homer-Dixon, "On the Threshold: Environmental Changes as Causes of Acute Conflict," *International Security*, vol. 16, no. 2, pp. 76–116 (1991).

11. Seventy-three cases are described in A. Carius, D. Tänzler, and J. Winterstein, *World Map of Environmental Conflicts* [in German] (Berlin: Adelphi Consult GmbH, 2006).

12. Partial aspects of the causal relationship between security, conflict, and climate impacts were discussed in the earlier research literature: N. Brown, "Climate, Ecology and International Security," *Survival*, vol. 31, no. 6, pp. 519–32 (1989); R. Swart, "Security Risks of Global Environmental Changes," *Global Environmental Change*, vol. 6, no. 3, pp. 187–92 (1999); Jürgen Scheffran, "Conflict Potential of Energy-Related Environmental Changes: The Case of Global Warming," [in German] in Wolfgang Bender, ed., *Verantwortbare Energieversorgung für die Zukunft* (Darmstadt: Technische Universität Darmstadt, 1997), pp. 179–218; A. Rahman, "Climate Change and Violent Conflicts," in Mohamed Suliman, ed., *Ecology, Politics and Violent Conflict* (London: Zed Books, 1999) pp. 181–210; J. Barnett, "Security and Climate Change," *Global Environmental Change*, vol. 13, no. 1, pp. 7–17, (2003).

13. W. Arnell, "Climate Change and Water Resources: A Global Perspective," in H. J. Schellnhuber et al., *Avoiding Dangerous Climate Change*, pp. 167–170.

14. Peter Gleick, "Effects of Climate Change on Shared Fresh Water Resources," in Irving

Mintzer, ed., *Confronting Climate Change* (Cambridge: Cambridge University Press, 1993) pp. 127–40; Kent Butts, "The Strategic Importance of Water," *Parameters*, vol. 27, no. 1, pp. 65–83 (1997); Manas Chatterji, Saul Arlosoroff, Gauri Guha, eds., *Conflict Management of Water Resources* (Burlington, Vermont: Ashgate Publishing, 2002); Sandra L. Postel, Aaron T. Wolf, "Dehydrating Conflict," *Foreign Policy*, September/October 2001, pp. 60–67.

15. Marc Levy, Catherine Thorkelson et al., "Freshwater Availability Anomalies and Outbreak of Internal War: Results from a Global Spatial Time Series Analysis," in the proceedings of international workshop "Human Security and Climate Change," held in Oslo, Norway, June 21–23, 2005.

16. J. Barnett, "Destabilising the Environment-Conflict Thesis," *Review of International Studies*, vol. 26, no. 2, pp. 271–88 (2000).

17. Norman Myers, "Environmental Refugees: A Growing Phenomenon of the 21st Century," *Philosophical Transactions of the Royal Society of London Series B-Biological Sciences*, vol. 357, no. 1,420, pp. 609–13.

18. Kurt M. Campbell et al., *The Age of Consequences: The Foreign Policy and National Security Implications of Global Climate Change* (Washington, D.C.: Center for Strategic and International Studies, 2007).

19. The CNA Corporation, "National Security and the Threat of Climate Change," 2007, available at securityandclimate.cna.org/report.

20. Campbell et al., *The Age of Consequences*.

21. Schubert et al., *Climate Change as a Security Risk*.

22. Mark Sandlow, "The Quest for National Security," *San Francisco Chronicle*, September 11, 2005.

23. Global Climate Change Security Oversight Act, *Congressional Record*, March 28, 2007 (Senate), pp. S4059–S4061; related is H. R. 1961, sponsored by Massachusetts Democratic Cong. Edward Markey. To date both bills are in the first step of the legislative process.

24. Dirk Ipsen, Roland Rösch, and Jürgen Scheffran, "Cooperation in Global Climate Policy: Potentialities and Limitations," *Energy Policy*, vol. 29, no. 4, pp. 315–26 (2001).

Global hot spots

CONTINUED FROM P. 25

1. A. Medzini, A. T. Wolf, "Towards a Middle East at Peace: Hidden Issues in Arab-Israeli Hydrogeopolitics," *International Journal of Water Resources Development*, vol. 20, no. 2, pp. 193–204 (2004); Hillel Shuval, Hassan Dweik, eds., *Water Resources in the Middle East: Israel-Palestinian Water Issues, From Conflict to Cooperation* (New York: Springer Verlag, 2007).

2. Schubert et al., *Climate Change as a Security*

Risk (Berlin: German Advisory Council on Global Change WBGU, 2007).

3. V. Percival and Thomas Homer-Dixon, "Environmental Scarcity and Violent Conflict: The Case of Rwanda," *Journal of Environment and Development*, vol. 5, no. 3, p. 270.

4. Gordon McGranahan, Deborah Balk, and Bridget Anderson, "The Rising Tide: Assessing the Risks of Climate Change and Human Settlements in Low Elevation Coastal Zones," *Environment and Urbanization*, vol. 19, no. 1, pp. 17–37 (2007).

5. International Federation of the Red Cross, "World Disasters Report 2002."

6. H. G. Brauch, "Climate Change, Environmental Stress and Conflict," in *Climate Change and Conflict* (Berlin: German Federal Ministry for the Environment, 2002).

Inside the atomic patent office

CONTINUED FROM P. 31

1. Memo by William A. Shurcliff, May 14, 1942, in microfilm collection M1392, "[Vannevar] Bush-[James] Conant File Relating the Development of the Atomic Bomb, 1940–1945" (hereafter called "BC"), Folder 14, "Material from Liaison Office Files—Primarily Shurcliff's Relations to S-1 Activities, Folder No. 2 [1942]" (hereafter "Material [1942]"), Roll 3, Target 1, Frame 172. Records of the OSRD, RG 227, National Archives and Records Administration (NARA), Washington, D.C.

2. William A. Shurcliff, "William A. Shurcliff: A Brief Autobiography" (Cambridge, Mass., unpublished manuscript, December 15, 1992), copy in Houghton Library, Harvard University, pp. 53–55, 187.

3. Margaret Gowing, *Britain and Atomic Energy, 1939–1945* (New York: St. Martin's, 1964), pp. 201–15; Spencer R. Weart, *Scientists in Power* (Cambridge: Harvard University Press, 1979), pp. 93–102, 170–77.

4. Letter from Vannevar Bush to Conway Coe, March 7, 1942, in "BC," Folder 6, "Patent Matters [1941–1945]," Roll 2, Target 1, Frame 4.

5. On the World War I patent secrecy law, the most interesting sources are the hearings in the *Congressional Record*: Hearings before the Committee on Patents, U.S. House of Representatives, 65th Cong., 1st sess., on H.R. 5269, July 13, 1917, pp. 3–10. On 1940–1941 revisions to the law, see: Unpublished Hearings before the Committee on Patents, U.S. House of Representatives, 76th Cong., 3rd sess., on H.R. 9928, May 31, 1940, and June 3, 1940; Hearings before the Committee on Patents, U.S. House of Representatives, 77th Cong., 1st sess., on H.R. 3359 and H.R. 3360, February 20, 1941–April 23, 1941, pp. 1–376.

6. The patent's expiration date would not begin until after the patent itself was granted, and the law specified that the inventor could sue for

compensation had the government been using the patent during the time it was secret. If the government had not used the patent, the inventor would not be entitled to any compensation.

7. Letter from Vannevar Bush to Conway Coe, April 30, 1942, in "BC," Folder 6, "Patent Matters [1941-1945]," Roll 2, Target 1, Frame 9.

8. *Ibid.*

9. Memo by Shurcliff, May 14, 1942. Emphasis in original.

10. William A. Shurcliff, "Chi[cago] Notes of 5/29/42 and 5/30/42," May 1942, in "BC," Folder 14, "Material [1942]," Roll 3, Target 1; William A. Shurcliff, "Brief History of WAS S-1 Patent Work," compiled from June 2, 1942 through at least September 30, 1942, in "BC," Folder 14, "Material [1942]," Roll 3, Target 1, Frame 154.

11. Memo by William A. Shurcliff, forwarded to both Vannevar Bush and James Conant, "7/1/42 Progress Report on W.A.S. Secrecy Efforts Relating to Patent Applications Bearing on S-1 Subjects," July 1, 1942, in "BC," Folder 147, "Patents [1942-1944]," Roll 10, Target 5, Frame 291; Memo by William A. Shurcliff, "Manner of Obtaining Names for LAI Cards," compiled from June 2, 1942, through August 15, 1942, in "BC," Folder 14, "Material [1942]," Roll 3, Target 1, Frame 150; Letter from William A. Shurcliff to Joseph Morris, National Academy of Sciences, June 25, 1942, in "BC," Folder 14, "Material [1942]," Roll 3, Target 1, Frame 82.

12. Letter from William A. Shurcliff to Vannevar Bush, September 25, 1942, in "BC," Folder 14, "Material [1942]," Roll 3, Target 1, Frame 38.

13. Shurcliff, *A Brief Autobiography*, pp. 59-60.

14. The patent in question (No. 2,297,305) was to Donald W. Kerst for a magnetic induction accelerator—an electron accelerator. "While this particular case is probably not of importance," Bush chastised the Patent Office, "the issuance of the patent indicates that our procedure is not air-tight." Letter from Vannevar Bush to Conway Coe, October 7, 1942, in "BC," Folder 14, "Material [1942]," Roll 3, Target 1, Frame 27. The article mentioning the patent was "Another Bomb Sight is Patented; One Device Corrects Plane's Aim," *New York Times*, October 4, 1942, p. A1.

15. Letter from William A. Shurcliff to Robert Lavender, March 29, 1943, in "BC," Folder 13, "Material from Liaison Office Files—Primarily Shurcliff's Relations to S-1 Activities, Folder No. 1 [1942-1944]" (hereafter "Material [1942-1944]"), Roll 2, Target 8, Frame 840. Shurcliff's concern with the petroleum industry and organic chemistry in general probably stemmed from his correspondence with representatives at Standard Oil Development Co. who had a large contract for developing gas centrifuge enrichment technology (which was not, in the end, used during the war).

16. Letter from Thomas Murphy, assistant commissioner of patents, to Lawrence H. Johnston, May 20, 1953, regarding "Detonating Apparatus" (U.S. Application 165,171; later granted as U.S. Patent 3,955,505). Copy of letter courtesy of Lawrence H. Johnson.

17. Letter from Sol B. Wiczer to William A.

Shurcliff, March 16, 1944, in "BC," Folder 13, "Material [1942-1944]," Roll 2, Target 8, Frame 816.

18. William A. Shurcliff, notes, February 1, 1943, in "BC," Folder 13, "Material [1942-1944]," Roll 2, Target 8, Frame 752.

19. Letter from William A. Shurcliff to Carroll L. Wilson, March 20, 1944, in "BC," Folder 13, "Material [1942-1944]," Roll 2, Target 8, Frame 811.

20. *Ibid.*

21. *Ibid.*

22. Letter from Carroll L. Wilson to John Lansdale Jr., March 22, 1944, in "BC," Folder 6, "Patent Matters [1941-1945]," Roll 2, Target 1, Frame 77; Letter from John Lansdale to Carroll L. Wilson, April 4, 1944, in "BC," Folder 13, "Material [1942-1944]," Roll 2, Target 8, Frame 808. For more information on Lansdale, see Gregg Herken, *Brotherhood of the Bomb: The Tangled Lives and Loyalties of Robert Oppenheimer, Ernest Lawrence, and Edward Teller* (New York: Henry Holt and Co., 2002), especially pp. 58-59.

23. Shurcliff, *A Brief Autobiography*, p. 187. Shurcliff was later known, among other things, for leading a strong opposition to the use of supersonic transport jets in the United States and for being an expert on solar energy. He passed away on June 20, 2006.

24. Memo from William A. Shurcliff to David Z. Beckler, "Remarks on Shurcliff's Files on S-1-Type Patent Application Data and on Secrecy Recommendations Thereon," October 31, 1944, in "BC," Folder 6, "Patent Matters [1941-1945]," Roll 2, Target 1, Frame 107.

25. "Manhattan District History: Book I—General, Volume 13—Patents," December 13, 1946, in Manhattan Project: Official History and Documents [microform] (Washington, D.C.: University Publications America, 1977), sec. 5, pp. 1-4.

26. For more details on Bush's efforts, see Alex Wellerstein, "Patenting the Bomb: Nuclear Weapons, Intellectual Property, and Technological Control," *Isis*, vol. 99, no. 1, pp. 5-12 (2008).

27. Carol S. Gruber, "Manhattan Project Maverick: The Case of Leo Szilard," *Prologue*, vol. 15, no. 2, pp. 73-87 (1987); Richard Rhodes, *The Making of the Atomic Bomb* (New York: Simon & Schuster, 1986), pp. 503-7.

28. Little has been written on the plutonium patents dispute. There are extensive records of it in the Glenn T. Seaborg Papers, Library of Congress, especially boxes 832-37, and in the "BC" files, among other places.

29. Information on Lavender's earlier navy activities can be found in his biographical statement in: "Statement of Robert A. Lavender, Economic Aspects of Government Patent Policies," Hearing before the Subcommittee on Monopoly of the Select Committee on Small Business, U.S. Senate, 88th Cong., 1st sess., March 14, 1963, pp. 274-81, on pp. 275-76.

30. A provocative article that discusses at length Groves' concerns about the possibility of post-war accountability in general is Stanley Goldberg, "General Groves and the Atomic West: The Making and Meaning of Hanford," in Bruce Hevly and John M. Findlay, eds., *The Atomic West*

(Seattle: University of Washington Press, 1998), pp. 39-89.

31. A recent book on the subject of the development of the bomb's "specialness" is Michael D. Gordin, *Five Days in August: How World War II Became a Nuclear War* (Princeton: Princeton University Press, 2007).

32. Memo from Leslie R. Groves and Military Policy Committee to Henry A. Wallace, Henry L. Stimson, and George C. Marshall, "Present Status and Future Program on Atomic Fission Bombs," August 21, 1943, in Harrison-Bundy Files Relating to the Development of the Atomic Bomb, 1942-1946, NARA, Washington, D.C., microfilm publication M1108, Folder 6, "Military Policy Committee Papers—Minutes," Roll 1, Target 6.

33. Vannevar Bush, *Pieces of the Action* (New York: Morrow, 1970), p. 84. In this passage he was specifically referring to the MIT Radiation Laboratory patent program, which also involved assigning patents to the government.

The system's components

CONTINUED FROM P. 35

1. Bettina Haymann Chavanne, "Ballistic Missile Defense Elements Modified for Europe," *Aerospace Daily and Defense Report*, October 4, 2007.

2. Military Electronics Briefing, "BMD X-Band Radars & BMD C4I," Teal Group Corporation, July 2007. Another source describes its upgrade potential as being "greater than 50,000 elements." J. F. Crawford, E. Reed, J. J. Hines, and D. R. Schmidt, "Ground Based Radar—Prototype Antenna," National Conference on Antennas and Propagation, IEE Conference Publication, no. 469, 1999.

3. The European midcourse radar would suffer from a similar limitation if targets are separated by angles greater than 50 degrees.

4. George N. Lewis and Theodore A. Postol, "European Missile Defense: The Technological Basis of Russian Concerns," *Arms Control Today*, October 2007, pp. 13-18.

Denuclearizing North Korea

CONTINUED FROM P. 49

1. The Joint Statement of the Fourth Round of the Six-Party Talks Beijing, September 19, 2005, can be found on the U.S. State Department website, www.state.gov/r/pa/prs/ps/2005/53490.htm.

2. Personal communications with Chinese nuclear specialists, November 2006.

3. Siegfried S. Hecker and William Liou, "Dangerous Dealings: North Korea's Nuclear Capabilities and the Threat of Export to Iran," *Arms*