

Evolution of monogamous marriage by maximization of inclusive fitness

L. FORTUNATO*¹ & M. ARCHETTI†²

*Department of Anthropology, University College London, London, UK

†Department of Zoology, University of Oxford, Oxford, UK

Keywords:

human behavioural ecology;
human social behaviour;
inclusive fitness;
kin selection;
marriage;
monogamy;
paternity;
polygyny;
social norms;
strategic behaviour;
wealth inheritance.

Abstract

The majority of human societies allow polygynous marriage, and the prevalence of this practice is readily understood in evolutionary terms. Why some societies prescribe monogamous marriage is however not clear: current evolutionary explanations—that social monogamy increases within-group co-operation, giving societies an advantage in competition with other groups—conflict with the historical and ethnographic evidence. We show that, within the framework of inclusive fitness theory, monogamous marriage can be viewed as the outcome of the strategic behaviour of males and females in the allocation of resources to the next generation. Where resources are transferred across generations, social monogamy can be advantageous if partitioning of resources among the offspring of multiple wives causes a depletion of their fitness value, and/or if females grant husbands higher fidelity in exchange for exclusive investment of resources in their offspring. This may explain why monogamous marriage prevailed among the historical societies of Eurasia: here, intensive agriculture led to scarcity of land, with depletion in the value of estates through partitioning among multiple heirs. Norms promoting high paternity were common among ancient societies in the region, and may have further facilitated the establishment of social monogamy. In line with the historical and ethnographic evidence, this suggests that monogamous marriage emerged in Eurasia following the adoption of intensive agriculture, as ownership of land became critical to productive and reproductive success.

Introduction

Background

Eighty-three percent of human societies allow polygynous marriage (Murdock & White, 1969; Murdock & Wilson, 1972). In humans, as in other sexually reproducing species, the lower investment in gametes by males

Correspondence: Laura Fortunato, Department of Anthropology, University College London, 14 Taviton Street, London WC1H 0BW, UK. Tel.: +44 (0) 20 7679 5463; fax: +44 (0) 20 7679 8632; e-mail: l.fortunato@ucl.ac.uk

¹Present address: School of Biology, University of St Andrews, Queen's Terrace, St Andrews, Fife KY16 9TS, UK

²Present address: Department of Organismic and Evolutionary Biology, Harvard University, 26 Oxford Street, Cambridge, MA 02138, USA

leads to the higher potential rate of reproduction of individual males relative to individual females. This, coupled with proximate constraints such as internal gestation and lactation, produces the typical mammalian pattern of polygynous breeding, characterized by high male investment in mating effort and high female investment in parental effort (Trivers, 1972; Clutton-Brock & Vincent, 1991). Extension of this paradigm to human social systems is used to explain the cross-cultural prevalence of polygynous marriage (e.g. Low, 2003, 2007; Marlowe, 2003). In some societies that allow polygynous marriage the majority of men may be each married to a single wife, because few command sufficient skill or resources to marry polygynously (White, 1988). This marriage pattern, sometimes referred to as

'monogamy' (e.g. Marlowe, 2003), is common among foragers and likely evolved because of the benefits of biparental care to offspring survival (Low, 2003, 2007).

This is distinct from the system of social monogamy found in the remaining 17% of societies, in which polygynous marriage is forbidden or disapproved (Murdock & White, 1969; Murdock & Wilson, 1972). Current evolutionary explanations view this marriage strategy as a mechanism of reproductive levelling (e.g. Alexander *et al.*, 1979; Alexander, 1987; Bowles *et al.*, 2003). A system of 'socially imposed monogamy' (Alexander *et al.*, 1979, p. 420) would reduce within-group competition by suppressing differences in reproductive success among men. Because of the attendant increase in within-group co-operation, societies adopting this strategy would have an advantage in competition with other groups. This would enable the cohesion of increasingly larger societies, ultimately leading to the formation of large nations (Alexander *et al.*, 1979; Alexander, 1987). However, social monogamy long predates the establishment of large nation states (Herlihy, 1995): while the diffusion of norms prescribing monogamous marriage is commonly attributed to the spread of Christianity, restrictions on polygynous marriage appear in the earliest historical records (Westermarck, 1921). For instance, Babylonian men were legally entitled to an additional wife only under special circumstances, such as illness or infertility of the first (as documented by the *Codex Hammurabi*, early second millennium BCE); strict monogamy is the only legally recognized form of marriage documented for ancient Greece and Rome (Herlihy, 1995; Scheidel, 2009).

More importantly, the 'socially imposed monogamy' model rests on the assumption that monogamous marriage significantly reduces the variance in male reproductive success (Alexander *et al.*, 1979). However, the historical and ethnographic evidence show that dominant individuals invariably attain extraordinary reproductive success even where marriage is strictly monogamous (Herlihy, 1995; Low, 2003; Scheidel, 2009). Ancient Rome is a case in point: despite the fanatical prescription of monogamous marriage, wealthy men fathered children by large numbers of slave women (Betzig, 1992a,b; Herlihy, 1995; Scheidel, 2009). Consistently, across data for 18 modern populations collated by Brown *et al.* (2009) we found no significant difference in variance in male reproductive success between societies practising monogamous marriage ($n = 6$, median: 10.0, range: 2.3–23.6) and societies practising polygynous marriage ($n = 12$, median: 10.4, range: 8.1–24.4) [Mann–Whitney $U = 27.00$, $z = -0.84$, n.s., $r = -0.20$. We coded societies on marriage strategy based on information in the original references in Brown *et al.* (2009), or references therein; our coding corresponds to the mating system coding in Brown *et al.* (2009), except for the Pimbwe, Dobe !Kung, and Ache, which we coded as practising polygynous marriage].

This evidence suggests that monogamous marriage may have evolved as a form of 'monogamous transfer' of a man's resources rather than as a form of monogamous mating.

Objectives and rationale

Here we address the question of the function of marriage strategies, that is, of their adaptive value in terms of differential reproduction, and show that the evolution of monogamous marriage can be understood within the framework of inclusive fitness theory (Hamilton, 1964a,b). At this ultimate level of explanation, we can ask evolutionary questions about cultural behaviours—that is, behaviours that are acquired through social transmission (Richerson & Boyd, 2005)—without reference to the underlying mechanism of transmission (Dunbar & Barrett, 2007). How a given behaviour is transmitted, whether genetically or through social learning, is a proximate question (West *et al.*, 2007).

We proceed in three steps. In the remainder of this section, we identify two candidate factors that can make social monogamy, as a form of 'monogamous transfer' of resources, advantageous over alternative marriage strategies. Next, we develop a game-theoretic model of the strategic behaviour of males and females in the allocation of resources to the next generation to show that these factors can indeed result in monogamous marriage as a stable evolutionary strategy. Finally, we discuss previous anthropological observations on the history and cross-cultural distribution of marriage strategies in the context of the model, and briefly outline specific predictions to be tested against the archaeological, historical, and ethnographic data.

Evolutionary accounts of marriage strategies typically assume that male reproductive success is constrained by access to females. However, in traditional human societies where individuals hold rights to property, inherited wealth is a key determinant of reproductive success, and reproductive opportunities may be constrained more by ownership of resources than by access to mates. In these societies, individuals are expected to transfer resources across generations in ways that maximize the effect of the resources on their inclusive fitness (Rogers, 1990; Hrdy & Judge, 1993). To the extent that there is a trade-off between transmitting genes and transmitting wealth to the next generation (Rogers, 1990), in some cases the optimal strategy may be to concentrate resources in a limited number of heirs. By definition, social monogamy channels a man's property to the offspring of a single wife; additionally, unigeniture (e.g. primo- or ultimo-geniture) may be used to avoid partitioning resources among them. In contrast, the property of a polygynous man is typically divided among his wives' offspring (although unigeniture may apply *within* sets of siblings by the same mother) (Gray, 1964; Mair, 1971; Goody, 1976). This suggests that social monogamy may be

advantageous where partitioning of resources causes a depletion of their fitness value.

But in humans, as in other sexually reproducing species, the reproductive interests of individuals in a socially monogamous pair only coincide if the male is the biological father of the female's offspring (Alexander, 1987). Therefore, males need to balance the benefit of investing in closely related heirs with the risk of investing in someone else's offspring. If a man has a low probability of being the biological father of his wife's children, he may be better off investing in his sister's: relatedness to a sister is always certain (through one's mother), as is relatedness to her offspring (Alexander, 1974; Greene, 1978). In fact, the transfer of a man's property to his sister's sons is common across societies with frequent female extramarital sex (Flinn, 1981; Hartung, 1981). We extend this reasoning to incorporate the strategic behaviour of females: if natural selection favours males who allocate resources based on their level of paternity, in turn it may favour females who allocate paternity based on the degree of male investment in their offspring. The resulting trade-off between paternity and investment of resources may lead to social monogamy: males would benefit from increased levels of paternity in their wife's offspring, and females from exclusive investment of their husband's resources in their own offspring. Of course, this mechanism can only operate if males have cues about paternity. In humans, in addition to direct phenotypic cues (see discussion in Geary, 2006), indirect behavioural cues may include the conformity of females to norms regulating their sexual behaviour; such norms are found in the vast majority of societies (Broude & Greene, 1976).

Theoretical framework

We capture these intuitive arguments with a game-theoretic model, described in detail in the Supporting Information. We focus on a population in which both males and females marry either monogamously or polygamously, with $w \geq 1$ wives for males and $h \geq 1$ husbands for females. Males transfer resources to the next generation 'vertically' to their wives' offspring or 'diagonally' to their sister's offspring (Fig. 1). Females produce one male and one female offspring; each sibling pair inherits resources δ from the parent generation, with $\delta = \delta_m + \delta_f = 1$ in a monogamous population in which all males transfer vertically, and $0 \leq \delta_m \leq 1$ and $0 \leq \delta_f \leq 1$ the male and female contributions to δ . The fitness of each sibling pair is given by δ^z , with $z > 0$; for $z > 1$, the fitness value of δ is depleted when δ is partitioned among the offspring of multiple wives.

The probability p that a male is the biological father of his wife's offspring depends on the behaviour of females, who give their husbands either 'high' paternity p_H or 'low' paternity p_L , with $0 < p_L < p_H \leq 1$. Females obtain an additional generic advantage α from mating with

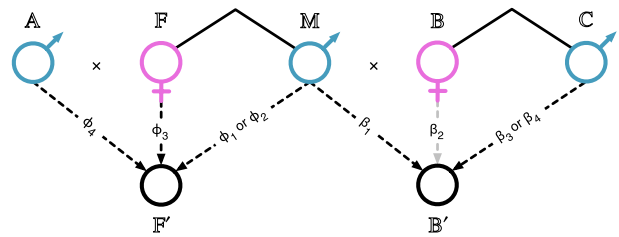

Fig. 1 Inclusive fitness contributions for a focal male M and a focal female F . In the parent generation crosses represent marriages, solid lines represent brother-sister relationships (A : F 's husband; B : M 's wife; C : B 's brother). In the offspring generation B' and F' each represent a sibling pair (B' : B 's offspring; F' : F 's offspring). Dashed arrows represent resource transfers from parent to offspring generation. β_i represents resources transferred to B' (β_1 if M transfers vertically; β_2 if B is polyandrous and her other husbands, excluding M , transfer vertically; β_3 if C does not marry; β_4 if C marries and transfers diagonally); β_2 is grey to indicate that the resources are transferred by B 's husbands other than M (which are not shown), rather than by B herself. ϕ_i represents resources transferred to F' (ϕ_1 if M does not marry; ϕ_2 if M marries and transfers diagonally; ϕ_3 if F does not marry; ϕ_4 if F marries and A transfers vertically). See text and SI Text for details.

other males besides their husbands, with $\alpha_L > \alpha_H$, and $\alpha_H = 0$ for $p_H = 1$. Males can infer their level of paternity from phenotypic or behavioural cues.

Schematically, the inclusive fitness payoff for a focal male M in the parent generation is given by the fitness value of resources β_i , inherited by the offspring B' of his $w \geq 1$ wives, plus the fitness value of resources ϕ_i , inherited by his sister's offspring F' , each scaled by the respective coefficient of relatedness ($r_{MB'}$ or $r_{MF'}$) (Fig. 1; Table 1; SI Text). The subscript $i = 1, \dots, 4$ denotes the pathway through which resources are transferred to the heir, as per Fig. 1; $\dot{w} \neq w$ for a mutant focal male whose marriage strategy differs from the strategy of resident males, and $\dot{w} = w$ in all other cases. Resources are divided equally among the male's wives' offspring. This can be written as

$$E_M = \dot{w} \left(\frac{\beta_1 + \beta_2 + \beta_3 + \beta_4}{w} \right)^z r_{MB'} + (\phi_1 + \phi_2 + \phi_3 + \phi_4)^z r_{MF'}$$

Similarly, the inclusive fitness payoff for a focal female F is given by the fitness value of resources β_i , inherited by the offspring B' of her brother's w wives, plus the fitness value of resources ϕ_i , inherited by her offspring F' , each scaled by the respective coefficient of relatedness ($r_{FB'}$ or $r_{FF'}$), plus any advantage $\dot{\alpha}$ she obtains from mating with other males besides her husbands (Fig. 1; Table 1; SI Text). As in the previous case, the subscript $i = 1, \dots, 4$ denotes the pathway through which resources are transferred to the heir, as per Fig. 1; $\dot{\alpha} \neq \alpha$ for a mutant focal female whose paternity strategy differs from the strategy of resident females, and $\dot{\alpha} = \alpha$ in all other cases. This can be written as

Symbol*	Focal individual	
	M	F
Resource transfers to B' (β_i)		
β_1	$\Omega \overset{\circ}{m}_V[\delta_m + \overset{\circ}{w}(\delta_i/h)]$	$\Omega m_V[\delta_m + w(\delta_i/h)]$
β_2	$\Omega \overset{\circ}{w} m_V(h-1)(\delta_m/w + \delta_i/h)$	$\Omega w m_V(h-1)(\delta_m/w + \delta_i/h)$
β_3	$\Omega \overset{\circ}{w}(1-\Omega)\delta_m$	$\Omega w(1-\Omega)\delta_m$
β_4	$\Omega \overset{\circ}{w} \Omega m_D[\delta_m + \overset{\circ}{w}(\delta_i/h)]$	$\Omega w \Omega m_D[\delta_m + w(\delta_i/h)]$
Resource transfers to F' (ϕ_i)		
ϕ_1	$(1-\Omega)\delta_m$	$(1-\Omega)\delta_m$
ϕ_2	$\Omega \overset{\circ}{m}_D[\delta_m + \overset{\circ}{w}(\delta_i/h)]$	$\Omega m_D[\delta_m + w(\delta_i/h)]$
ϕ_3	$(1-\Phi)\delta_i$	$(1-\Phi)\delta_i$
ϕ_4	$\Phi h m_V(\delta_m/w + \delta_i/h)$	$\Phi h \overset{\circ}{m}_V(\delta_m/w + \delta_i/h)$
Coefficients of relatedness (r_{xy})		
to B'	$[\overset{\circ}{\rho} + (h-1)\rho]/2h^2$	$(\rho/2h)[(1+\rho^2/h)/4]$
to F'	$(1/2)[(1+\rho^2/h)/4]$	$1/2$

Table 1 Symbols used in the inclusive fitness payoffs.

*The subscript $i = 1, \dots, 4$ to β and ϕ denotes the pathway through which resources are transferred to the heir, while the subscripts to r denote the focal individual (M or F) and heir y (B' or F'), as per Fig. 1. Ω denotes the marriage probability for males, Φ the marriage probability for females. m_V denotes the probability that a male transfers vertically, $m_D = 1 - m_V$ the probability that he transfers diagonally. $\overset{\circ}$ indicates any attribute that may depend on the relevant strategy for the focal individual, such that its value may differ from the corresponding value for the resident population. See SI Text for details.

$$E_F = w \left(\frac{\beta_1 + \beta_2 + \beta_3 + \beta_4}{w} \right)^z r_{FB'} + (\phi_1 + \phi_2 + \phi_3 + \phi_4)^z r_{FF'} + \overset{\circ}{\alpha}$$

The possible combinations of male and female strategies differ in inclusive fitness payoffs; given these payoffs, we can derive evolutionarily stable equilibria consisting of a pair of male and female strategies that cannot be

invaded by rare mutants playing alternative strategies (Maynard Smith, 1982) (SI Text).

Results

Social monogamy is a stable evolutionary outcome under two scenarios (SI Text and Table S1); both require 'suspicious' males, that is, males who transfer vertically if females are monogamous and provide 'high' paternity, diagonally otherwise. In the first scenario females always

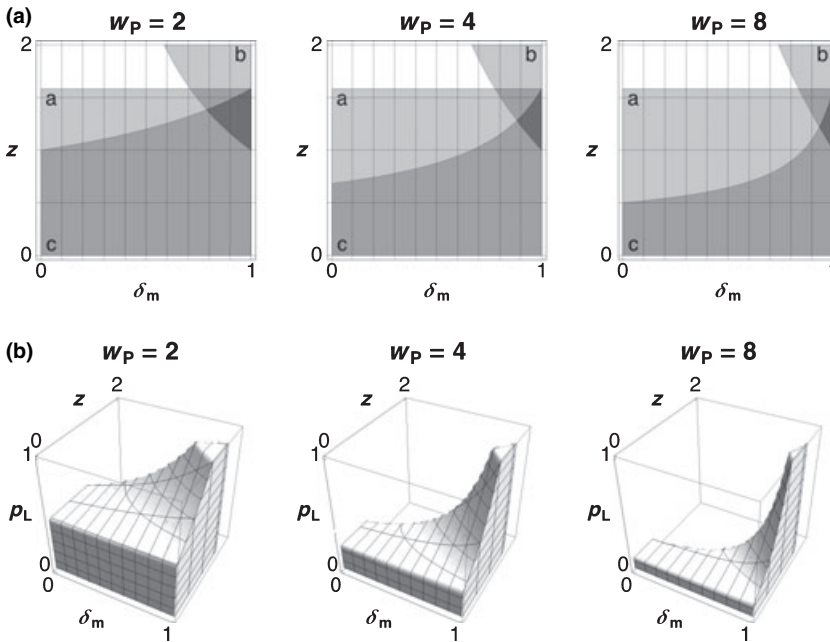

Fig. 2 Stability of 'suspicious' monogamous males against mutant males with $w_p = 2$, $w_p = 4$, or $w_p = 8$, for $p_H = 1$; w_p denotes the number of wives for polygynous males, and p_H the paternity level of males who always provide 'high' paternity and of monogamous males with 'astute' females. δ_m represents the relative male contribution to the resources transferred to the offspring generation; z describes the relationship between resources and individual fitness; p_L represents the paternity level of polygynous males with 'astute' females. See text and SI Text for details. (a), with monogamous females who always provide 'high' paternity. **a** is the condition for stability against monogamous males who transfer diagonally, **b** against polygynous males who transfer vertically, **c** against polygynous males who transfer diagonally (see Table 2). Monogamy is stable in the darker area, where all conditions are met. (b), with 'astute' monogamous females. Monogamy is stable throughout the volume shown.

Table 2 Conditions for the stability of 'suspicious' monogamous males for $p_H = 1$.

Notation*	Condition†	Strategy of mutant males
a	$z < \log 3 / \log 2$	Monogamous marriage with diagonal transfer
b‡	$w_P(\delta_m/w_P + \delta_l)^z p_L < 1$	Polygynous marriage with vertical transfer
c	$(2\delta_m + \delta_l + w_P\delta_l)^z < 3$	Polygynous marriage with diagonal transfer

*Corresponds to the notation used in Fig. 2a. See SI Text for details.

† $w_P > 1$ denotes the number of wives for a polygynous male.

‡ $p_L = 1$ with females who always provide 'high' paternity.

provide 'high' paternity. In the second scenario females are 'astute', that is, they provide 'high' paternity if males are monogamous, 'low' paternity otherwise. Both combinations of male and female strategies result in monogamous marriage, vertical transfer, and 'high' paternity.

Figure 2 illustrates the two scenarios for $p_H = 1$. In the first case, monogamy can be advantageous where there is a fitness cost to dividing resources among the offspring of multiple wives (i.e. for $z > 1$; condition **b** in Table 2; Fig. 2a). In the second case, because of the strategic behaviour of females, polygynous males suffer a reduction in relatedness to wives' offspring; consequently, monogamy can be advantageous irrespective of whether the fitness value of resources is depleted through division (i.e. for $z > 0$; condition **b** in Table 2; Fig. 2b). Vertical transfer can be advantageous where the benefit to a man of providing extra resources to his sister's offspring is offset by their lower relatedness relative to wife's offspring (i.e. for z below the threshold specified by condition **c** in Table 2; Fig. 2a and b). Monogamy and vertical transfer become increasingly advantageous as each wife provides a relatively smaller share of the resources inherited by her offspring (i.e. as δ_m increases and/or w_P decreases; conditions **b** and **c** in Table 2; Fig. 2a and b). Additionally, in the second case the benefit to monogamy increases as the relatedness between a polygynous male and his wives' offspring decreases (i.e. as p_L decreases; for $p_L < 1/w_P$, any potential fitness benefit to polygyny is offset by the reduction in relatedness to wives' offspring, such that monogamy is stable for all values of δ_m ; condition **b** in Table 2; Fig. 2b).

Figure S1 shows that these results hold for values of $p_H < 1$. Here $p_H = 0.5$, which is likely an extremely low value of p_H : men would attain on average as much reproductive success by other men's wives as by their own in a society with a paternity level of $p < 0.5$ (Hartung, 1981). For comparison, in contemporary populations men are the biological fathers of their putative children, on average, in 98.3% of cases if they have high confidence of paternity, and in 70.2% of cases if they have low confidence of paternity; actual paternity levels

must fall between these values for most societies (Anderson, 2006). Assuming that comparable paternity levels characterized our species' recent evolutionary past, this suggests that social monogamy represented a stable outcome in the evolution of human social systems.

Discussion

We developed a game-theoretic model to investigate whether monogamous marriage can be viewed as the outcome of the strategic behaviour of males and females in the allocation of resources to the next generation. The model showed that where resources are linked to fitness and are transferred across generations, social monogamy can be a stable evolutionary outcome (i) if dividing resources among the offspring of multiple wives causes a depletion of their fitness value, and/or (ii) if females grant husbands higher fidelity in exchange for exclusive investment of resources in their offspring. In both cases, the benefit to monogamy increases as the relative contribution of resources by females decreases.

These findings suggest that monogamous marriage can be understood within the framework of inclusive fitness theory. In turn, this challenges previous evolutionary explanations for the emergence of monogamous marriage, and for variation in marriage strategies across societies more generally: the former assume the implication of group-level processes, while both assume that male reproductive success is always maximized by polygynous marriage or, equivalently, that variance in male reproductive success is always greater under polygynous than under monogamous marriage (Low, 2003, 2007). The framework we develop makes both assumptions unnecessary. Rather, it shows that where resources are transferred across generations and are linked to fitness, whether monogamous or polygynous marriage represents the optimal strategy for males depends on whether the value of the resources they provide is depleted through division among multiple heirs; some form of division is inevitable if multiple wives are involved.

Further, this framework extends current evolutionary explanations for transfer strategies, which rely on the notion of strategic male behaviour (e.g. Alexander, 1974; Greene, 1978; Kurland, 1979), to incorporate the strategic behaviour of females: if selection favours males who allocate resources strategically, based on their level of paternity, it is also likely to favour females who allocate paternity strategically, based on the level of male investment in their offspring. This simple extension has important implications for analysis of the evolution of marriage strategies, leading to a situation where both males and females stand to gain from monogamous marriage: males benefit from investing resources 'safely' in the individuals in the next generation that provide the greatest potential fitness returns, that is, their wife's offspring; females, in turn, benefit from exclusive

investment of their husband's resources in their own offspring. In a similar way, this extension is likely to have important implications for analysis of the evolution of other aspects of human social organization that are linked to transfer strategies: for example, the notion of strategic male behaviour in this context underlies current explanations for the evolution of descent systems (see review in Cronk & Gerkey, 2007).

The historical and ethnographic evidence suggest that these mechanisms likely operated in shaping the evolution of human social systems. In the Old World, polygyny prevails among African societies with subsistence economies based on pastoralism or extensive agriculture (Goody, 1976). The relationship between resources and fitness documented for the Gabbra pastoralists of Kenya (Mace, 1996) and for the Chewa horticulturalists of Malawi (Holden *et al.*, 2003) indicates that in pastoralism and horticulture the fitness value of resources is not depleted through division. Among the Gabbra, for example, parents provide on average 10 camels to marry off a son: three as bridewealth to the bride's kin, and seven to the groom for starting an independent household (Mace, 1996). If the division of resources depleted their fitness value, the reproductive success of men owning five camels would be less than half the reproductive success of men owning 10. Conversely, men with five camels have more than half the reproductive success of men with 10 (Mace, 1996). This is likely because in both subsistence systems productivity is constrained more by availability of labour than by ownership of the primary productive resources (Goody, 1976): in pastoralist societies holdings of livestock can easily be increased through husbandry; in horticultural societies the low productivity afforded by extensive agricultural techniques means that land is rarely a scarce resource (Gray, 1964; Goody, 1976).

This is in stark contrast with the intensive agriculture practised in the historical societies of Eurasia, where irrigation and ploughing led to increased productivity, which in turn sustained continued population growth. Combined, increased productivity and population growth caused shortages of land. As land scarcity increased, so did the pressure to keep holdings above the minimum size required to set up a viable productive and reproductive unit (Goody, 1976; Hrdy & Judge, 1993). Under these conditions of habitat saturation, the partitioning of estates depleted their value; in extreme cases the reduction in value was so great that parents commonly designated a single heir, at the expense of all other offspring, through systems of unigeniture (Hrdy & Judge, 1993; e.g. Boone, 1986, 1988; Voland & Dunbar, 1995).

Consistent with our finding that social monogamy can be advantageous where the value of resources is depleted through division, marriage was typically monogamous in the agrarian societies of Eurasia with economies based on intensive agriculture (Goody, 1976). In line with our expectations, the relative contribution of women to

production is lower in these societies compared to other subsistence systems (Murdock & Provost, 1973; Goody, 1976). Indeed, across societies access to new land for expansion is a key ecological determinant of polygyny (White & Burton, 1988), and within societies the incidence of polygyny declines with increasing scarcity of land (White, 1988). This raises the possibility that restrictions on polygynous marriage emerged in the ancient societies of Eurasia following the adoption of intensive agriculture, as ownership of land became increasingly critical to economic success, and growing shortages of land imposed greater costs on partibility. Cultural norms promoting high paternity, such as ideologies of honour, virginity, and sexual fidelity, were common in these societies (Mair, 1971; Scheidel, 2009). To the extent that these norms resulted in an increase in average relatedness between a man and his wife's offspring, our findings suggest that they may have facilitated the establishment of social monogamy in this region.

The model generates the following predictions about the cross-cultural distribution and history of marriage strategies, to be tested against the ethnographic, archaeological, and historical data. First, the stability of monogamous marriage requires that men transfer resources vertically, that is, to their wife's offspring. Therefore, we predict the cross-cultural data to reveal an association between monogamous marriage and the transfer of a man's property to his wife's offspring. Second, we expect the archaeological evidence to show that the emergence of monogamous marriage was linked to the development of intensive agricultural techniques, possibly coupled with the establishment of social norms promoting high paternity. Analogous property considerations may help explain historically attested transitions between marriage strategies within societies, such as the recent shift from polygyny to monogamy in several Muslim countries, or the shift from monogamy to polygyny among the Mormons during the 19th century (Cairncross, 1974).

Of course, any model can capture but a small fraction of variation in human social systems, and must overlook the many historical contingencies, such as the diffusion of religious beliefs (e.g. Goody, 1983), that may have influenced their development. Yet placing this variation within an inclusive fitness framework allows us to conceptualize general evolutionary mechanisms shaping the organization of human societies. This finally resolves the crux of anthropological discussions about whether the primary function of marriage is 'economic and productive' or 'sexual and reproductive' (Goody, 1973, p. 189). In evolutionary terms, the proximate economic determinants of marriage underlie its ultimate reproductive function.

Acknowledgments

We thank A. Grafen, K. Laland, R. Mace, R. Sear, S. Shennan, J. Wettlaufer, and D. Yu for comments on the

manuscript, W. Scheidel for access to an unpublished manuscript, G. Brown for discussion of issues relating to the coding of mating systems versus marriage strategies, and C. El Mouden, A. Gardner, and two anonymous reviewers for feedback during the review process. L. F. was funded by the Economic and Social Research Council UK and by the UCL Graduate School. M. A. was supported by the Human Frontier Science Program Organization and by St John's College, Oxford.

References

- Alexander, R.D. 1974. The evolution of social behavior. *Annu. Rev. Ecol. Syst.* **5**: 325–383.
- Alexander, R.D. 1987. *The Biology of Moral Systems*. Aldine de Gruyter, Hawthorne.
- Alexander, R.D., Hoogland, J.L., Howard, R.D., Noonan, K.M., & Sherman, P.W. 1979. Sexual dimorphisms and breeding systems in pinnipeds, ungulates, primates, and humans. In: *Evolutionary Biology and Human Social Behavior: An Anthropological Perspective* (N.A. Chagnon & W. Irons, eds), pp. 402–435. Duxbury Press, North Scituate.
- Anderson, K.G. 2006. How well does paternity confidence match actual paternity? Evidence from worldwide nonpaternity rates. *Curr. Anthropol.* **47**: 513–520.
- Betzig, L. 1992a. Roman polygyny. *Ethol. Sociobiol.* **13**: 309–349.
- Betzig, L. 1992b. Roman monogamy. *Ethol. Sociobiol.* **13**: 351–383.
- Boone, J.L., 1986. Parental investment and elite family structure in preindustrial states: a case study of late medieval-early modern Portuguese genealogies. *Am. Anthropol.* **88**: 859–878.
- Boone, J.L., 1988. Parental investment, social subordination, and population processes among the 15th and 16th century Portuguese nobility. In: *Human Reproductive Behavior: A Darwinian Perspective* (L. Betzig, M. Borgerhoff Mulder & P. Turke, eds), pp. 201–219. Cambridge University Press, Cambridge.
- Bowles, S., Choi, J.-K. & Hopfensitz, A. 2003. The co-evolution of individual behaviors and social institutions. *J. Theor. Biol.* **223**: 135–147.
- Broude, G.J. & Greene, S.J. 1976. Cross-cultural codes on twenty sexual attitudes and practices. *Ethnology* **15**: 409–429.
- Brown, G.R., Laland, K.N. & Borgerhoff Mulder, M. 2009. Bateman's principles and human sex roles. *Trends Ecol. Evol.* **24**: 297–304.
- Cairncross, J. 1974. *After Polygamy was made a Sin: The Social History of Christian Polygamy*. Routledge & Kegan Paul, London.
- Clutton-Brock, T.H. & Vincent, A.C.J. 1991. Sexual selection and the potential reproductive rates of males and females. *Nature* **351**: 58–60.
- Cronk, L. & Gerkey, D. 2007. Kinship and descent. In: *Oxford Handbook of Evolutionary Psychology* (R.I.M. Dunbar & L. Barrett, eds), pp. 463–478. Oxford University Press, Oxford.
- Dunbar, R.I.M. & Barrett, L. 2007. Evolutionary psychology in the round. In: *Oxford Handbook of Evolutionary Psychology* (R.I.M. Dunbar & L. Barrett, eds), pp. 3–9. Oxford University Press, Oxford.
- Flinn, M. 1981. Uterine vs. agnatic kinship variability and associated cousin marriage preferences: an evolutionary biological analysis. In: *Natural Selection and Social Behavior: Recent Research and New Theory* (R.D. Alexander & D.W. Tinkle, eds), pp. 439–475. Chiron Press, New York.
- Geary, D.G. 2006. Coevolution of paternal investment and cuckoldry in humans. In: *Female Infidelity and Paternal Uncertainty: Evolutionary Perspectives on Male Anti-cuckoldry Tactics* (S.M. Platek & T.K. Shackelford, eds), pp. 14–34. Cambridge University Press, Cambridge.
- Goody, J. 1973. Polygyny, economy and the role of women. In: *The Character of Kinship* (J. Goody, ed.), pp. 175–190. Cambridge University Press, London.
- Goody, J. 1976. *Production and Reproduction: A Comparative Study of the Domestic Domain*. Cambridge University Press, Cambridge.
- Goody, J. 1983. *The Development of the Family and Marriage in Europe*. Cambridge University Press, Cambridge.
- Gray, R.F. 1964. Introduction. In: *The Family Estate in Africa: Studies in the Role of Property in Family Structure and Lineage Continuity* (R.F. Gray & P.H. Gulliver, eds), pp. 1–33. Routledge & Kegan Paul, London.
- Greene, P.J. 1978. Promiscuity, paternity, and culture. *Am. Ethnol.* **5**: 151–159.
- Hamilton, W.D. 1964a. The genetical evolution of social behaviour. I. *J. Theor. Biol.* **7**: 1–16.
- Hamilton, W.D. 1964b. The genetical evolution of social behaviour. II. *J. Theor. Biol.* **7**: 17–52.
- Hartung, J. 1981. Paternity and inheritance of wealth. *Nature* **291**: 652–654.
- Herlihy, D. 1995. Biology and history: the triumph of monogamy. *J. Interdiscipl. Hist.* **25**: 571–583.
- Holden, C.J., Sear, R. & Mace, R. 2003. Matriliney as daughter-biased investment. *Evol. Hum. Behav.* **24**: 99–112.
- Hrdy, S.B. & Judge, D.S. 1993. Darwin and the puzzle of primogeniture: an essay on biases in parental investment after death. *Hum. Nature* **4**: 1–45.
- Kurland, J.A. 1979. Paternity, mother's brother, and human sociality. In: *Evolutionary Biology and Human Social Behavior: An Anthropological Perspective* (N.A. Chagnon & W. Irons, eds), pp. 145–180. Duxbury Press, North Scituate, MA.
- Low, B.S. 2003. Ecological and social complexities in human monogamy. In: *Monogamy: Mating Strategies and Partnerships in Birds, Humans and Other Mammals* (U.H. Reichard & C. Boesch, eds), pp. 161–176. Cambridge University Press, Cambridge.
- Low, B.S. 2007. Ecological and socio-cultural impacts on mating and marriage systems. In: *Oxford Handbook of Evolutionary Psychology* (R.I.M. Dunbar & L. Barrett, eds), pp. 449–462. Oxford University Press, Oxford.
- Mace, R. 1996. Biased parental investment and reproductive success in Gabbra pastoralists. *Behav. Ecol. Sociobiol.* **38**: 75–81.
- Mair, L.P. 1971. *Marriage*. Penguin Books Ltd, Harmondsworth.
- Marlowe, F.W. 2003. The mating system of foragers in the Standard Cross-Cultural Sample. *Cross-Cult. Res.* **37**, 282–306.
- Maynard Smith, J. 1982. *Evolution and the Theory of Games*. Cambridge University Press, Cambridge.
- Murdock, G.P. & Provost, C. 1973. Factors in the division of labor by sex: a cross-cultural analysis. *Ethnology* **12**: 203–225.
- Murdock, G.P. & White, D.R. 1969. Standard cross-cultural sample. *Ethnology* **8**, 329–369.
- Murdock, G.P. & Wilson, S.F. 1972. Settlement patterns and community organization: cross-cultural codes 3. *Ethnology* **11**: 254–295.
- Richerson, P.J. & Boyd, R. 2005. *Not by Genes Alone: How Culture Transformed Human Evolution*. The University of Chicago Press, Chicago, IL.

- Rogers, A.R. 1990. Evolutionary economics of human reproduction. *Ethol. Sociobiol.* **11**: 479–495.
- Scheidel, W. 2009. Sex and empire: a Darwinian perspective. In: *The Dynamics of Ancient Empires: State Power from Assyria to Byzantium* (I. Morris & W. Scheidel, eds), pp. 255–324. Oxford University Press, New York, NY.
- Trivers, R.L. 1972. Parental investment and sexual selection. In: *Sexual Selection and the Descent of Man 1871–1971* (B. Campbell, ed.), pp. 136–179. Heinemann, London.
- Voland, E. & Dunbar, R.I.M. 1995. Resource competition and reproduction: the relationship between economic and parental strategies in the Krummhörn population (1720–1874). *Hum. Nature* **6**: 33–49.
- West, S.A., Griffin, A.S., & Gardner, A. 2007. Social semantics: altruism, cooperation, mutualism, strong reciprocity and group selection. *J. Evolution. Biol.* **20**: 415–432.
- Westermarck, E. 1921. *The History of Human Marriage, vol. 3*, 5th edn. MacMillan and Co., Ltd, London.
- White, D.R. 1988. Rethinking polygyny: co-wives, codes, and cultural systems. *Curr. Anthropol.* **29**: 529–572.
- White, D.R. & Burton, M.L. 1988. Causes of polygyny: ecology, economy, kinship, and warfare. *Am. Anthropol.* **90**: 871–887.

Supporting information

Additional Supporting Information may be found in the online version of this article:

Data S1 Theoretical framework.

Figure S1 Stability of ‘suspicious’ monogamous males for $p_H = 0.5$.

Table S1 Summary of the possible strategies.

Table S2 Symbols used in the model.

As a service to our authors and readers, this journal provides supporting information supplied by the authors. Such materials are peer-reviewed and may be re-organized for online delivery, but are not copy-edited or typeset. Technical support issues arising from supporting information (other than missing files) should be addressed to the authors.

Received 15 March 2009; accepted 6 October 2009

Evolution of monogamous marriage by maximization of inclusive fitness (supporting information)

Laura Fortunato^{1*} and Marco Archetti²

¹Department of Anthropology, University College London,
14 Taviton Street, London WC1H 0BW, United Kingdom

²Department of Zoology, University of Oxford,
South Parks Road, Oxford OX1 3PS, United Kingdom

*Corresponding author. E-mail: 1.fortunato@ucl.ac.uk

Theoretical framework

Male and female strategies

We consider a population with n males and n females, in which individuals marry either monogamously (M) or polygamously (P). We use $w \geq 1$ to denote the number of wives for males and $h \geq 1$ the number of husbands for females; males and females marry with probabilities Ω and Φ , respectively, which are derived below.

Each female produces one male and one female offspring. Unmarried females transfer their resources, denoted δ_f , to their own offspring, whereas unmarried males transfer their resources, denoted δ_m , to their sister's offspring. The resources of married females are controlled by their husbands, i.e. a male controls his own δ_m and a share $1/h$ of the δ_f of each of his w wives. Males transfer resources “vertically” to their wife's (or wives') offspring (V), with probability m_V , or “diagonally” to their sister's offspring (D), with probability m_D ; each male transfers either vertically or diagonally, i.e. m_V and m_D take values 0 or 1, and $m_V = 1 - m_D$. To simplify the notation, we assume that individuals in the parent generation transfer resources to sibling pairs rather than to individuals in the offspring generation. Each sibling pair inherits resources

δ , with $\delta = \delta_m + \delta_f = 1$ for the offspring of a monogamous couple in a monogamous population in which all males transfer vertically. The fitness of each sibling pair is given by δ^z , with $z > 0$. $\delta_{\mathbb{B}'}$ and $\delta_{\mathbb{F}'}$ denote the resources inherited by sibling pairs \mathbb{B}' and \mathbb{F}' , respectively (Figure 1 in the text).

The probability p that a male is the biological father of his wife’s offspring depends on the behaviour of females. Females give their husbands either “high” paternity p_H (H) or “low” paternity p_L (L), with $0 < p_L < p_H \leq 1$. Females obtain an additional generic advantage α from mating with other males besides their husbands; for example, α may represent genetic benefits which lead to increased offspring survival or resource benefits such as nuptial gifts (Reynolds 1996; Kokko 1999). We assume that $\alpha_L > \alpha_H$, and $\alpha_H = 0$ for $p_H = 1$. For simplicity, we further assume that $0 < \alpha < 1/2$, such that its fitness value is small relative to the value of the resources transferred to the offspring generation, and does not affect the amount of resources males transfer to their wives’ or sister’s offspring.

Both males and females know their spouses’ marriage strategy. The transfer strategy of males may be conditional upon the marriage and paternity strategies of females. A “suspicious” male (S) transfers vertically if his wives are monogamous and provide paternity p_H , diagonally otherwise. An “ingenuous” male (I) transfers diagonally if his wives are monogamous and provide paternity p_H , vertically otherwise. These strategies require that males have cues about paternity (e.g. Kokko 1999): in humans, these include direct phenotypic cues or indirect behavioural cues (e.g. the conformity of females to cultural norms regulating their sexual behaviour). The paternity strategy of females may be conditional only upon the marriage strategy of males. An “astute” female (A) provides paternity p_H if her husbands marry monogamously, p_L otherwise. A “naive” female (N) provides paternity p_L if her husbands marry monogamously, p_H otherwise.

Table S1 presents a summary of the strategies included in the game. We use XY to denote the marriage strategy X and transfer strategy Y for a male, XZ to denote the marriage strategy X and paternity strategy Z for a female, and (XY, XZ) to denote a pair of male and female strategies. For example, (MV, MH) represents the interaction of a monogamous male who transfers vertically, MV, with a monogamous female who always provides “high” paternity, MH. Table S2 presents a summary of all the symbols used in the model.

Table S1: Summary of the possible strategies**(a)** Male strategies

Strategy			
Attribute	Symbol	Behaviour	Description
Marriage (X)	M	Monogamous	Male marries one female only ($w = 1$)
	P	Polygynous	Male marries more than one female ($w > 1$)
Transfer (Y)	V	Vertical	Married male transfers resources to wives' offspring
	D	Diagonal	Married male transfers resources to sister's offspring
	S	Suspicious	Married male is V if wife is M and provides p_H , D otherwise
	I	Ingenuous	Married male is D if wife is M and provides p_H , V otherwise

(b) Female strategies

Strategy			
Attribute	Symbol	Behaviour	Description
Marriage (X)	M	Monogamous	Female marries one male only ($h = 1$)
	P	Polyandrous	Female marries more than one male ($h > 1$)
Paternity (Z)	H	High	Married female provides "high" paternity ($0 < p_H \leq 1, \alpha_H$)
	L	Low	Married female provides "low" paternity ($0 < p_L < 1, \alpha_L$)
	A	Astute	Married female provides p_H if husband is M, p_L otherwise
	N	Naive	Married female provides p_L if husband is M, p_H otherwise

Table S2: Symbols used in the model

Notation	Description
X: M, P	marriage strategy (of males and females)
Y: V, D, S, I	transfer strategy (of males)
Z: H, L, A, N	paternity strategy (of females)
n	number of individuals of each sex in the population
Ω, Φ	marriage probability for a male and for a female
m_M, m_P	frequency of monogamous and of polygynous males in the population
f_M, f_P	frequency of monogamous and of polyandrous females in the population
w, w_P	number of wives for a male (generic and for a polygynous male)
h	number of husbands for a female (generic)
$\delta, \delta_{\mathbb{B}'}, \delta_{\mathbb{F}'}$	resources inherited by a sibling pair in the offspring generation (generic, by sibling pair \mathbb{B}' , and by sibling pair \mathbb{F}')
δ_m, δ_f	relative male and female contribution to δ
z	describes the relationship between inherited resources and fitness, given by δ^z
m_V, m_D	probability that a male transfers vertically and diagonally
p, p_H, p_L	probability that a female's husband is the biological father of her offspring (generic, for a female who provides "high" paternity, and for a female who provides "low" paternity)
$\alpha, \alpha_H, \alpha_L$	advantage to a female of mating with other males besides her husbands (generic, for a female who provides "high" paternity, and for a female who provides "low" paternity)
\mathbb{M}, \mathbb{F}	focal male and female (or sibling to the focal individual)
A	\mathbb{F} 's husband
\mathbb{B}	\mathbb{M} 's wife
\mathbb{C}	\mathbb{B} 's brother
\mathbb{B}'	\mathbb{B} 's offspring
\mathbb{F}'	\mathbb{F} 's offspring
$E_{\mathbb{M}}, E_{\mathbb{F}}$	inclusive fitness for a focal male and for a focal female
β_i, ϕ_i	resources transferred to \mathbb{B}' and to \mathbb{F}'
r_{xy}	coefficient of relatedness of focal individual x (\mathbb{M} or \mathbb{F}) to heir y (\mathbb{B}' or \mathbb{F}')
\circ	denotes any attribute that may depend on the relevant strategy for the focal individual

Marriage probabilities

For simplicity, we assume that polygamous individuals either marry w or h spouses, or do not marry at all. Denoting m_M and m_P the frequencies of monogamous and polygynous males in the population, and f_M and f_P the frequencies of monogamous and polyandrous females, a focal monogamous male marries with probability

$$\Omega_M = \begin{cases} f_M \left[m_M \cdot 1 + m_P \frac{n}{(n-1)w+1} \right] + f_P \left[m_M \cdot 1 + m_P \frac{nh}{(n-1)w+1} \right] & \text{if } \frac{nh}{(n-1)w+1} \leq 1 \\ f_M \left[m_M \cdot 1 + m_P \frac{n}{(n-1)w+1} \right] + f_P [m_M \cdot 1 + m_P \cdot 1] & \text{if } \frac{nh}{(n-1)w+1} \geq 1 \end{cases} .$$

This is derived as follows:

- in a population of monogamous females and monogamous males there are n females, each requiring one husband, and n males, each requiring one wife; thus, the focal male marries with probability $\Omega_M = 1$;
- in a population of monogamous females and polygynous males there are n females, each requiring one husband, $n - 1$ resident polygynous males, each requiring w wives, and the focal monogamous male, requiring one wife; thus, the focal male marries with probability $\Omega_M = n/[(n-1)w+1]$;
- in a population of polyandrous females and monogamous males there are n females, each requiring h husbands, and n males, each requiring one wife; thus, the focal male marries with probability $\Omega_M = 1$;
- in a population of polyandrous females and polygynous males there are n females, each requiring h husbands, $n - 1$ resident polygynous males, each requiring w wives, and the focal monogamous male, requiring one wife; thus, the focal male marries with probability $\Omega_M = nh/[(n-1)w+1]$ if the number of potential wives is smaller than the number of wives required, i.e. if $nh/[(n-1)w+1] \leq 1$, or with probability $\Omega_M = 1$ if the number of potential wives is greater than the number of wives required, i.e. if $nh/[(n-1)w+1] \geq 1$.

By similar reasoning, a focal polygynous male marries with probability

$$\Omega_P = \begin{cases} f_M \left[m_M \frac{n}{(n-1) + w} + m_P \frac{1}{w} \right] + f_P \left[m_M \cdot 1 + m_P \frac{h}{w} \right] & \text{if } \frac{h}{w} \leq 1 \\ f_M \left[m_M \frac{n}{(n-1) + w} + m_P \frac{1}{w} \right] + f_P [m_M \cdot 1 + m_P \cdot 1] & \text{if } \frac{h}{w} \geq 1 \end{cases}.$$

Assuming that n is large relative to h and w , Ω_M and Ω_P simplify to

$$\Omega = \begin{cases} f_M \left(m_M \cdot 1 + m_P \frac{1}{w} \right) + f_P \left(m_M \cdot 1 + m_P \frac{h}{w} \right) & \text{if } \frac{h}{w} \leq 1 \\ f_M \left(m_M \cdot 1 + m_P \frac{1}{w} \right) + f_P (m_M \cdot 1 + m_P \cdot 1) & \text{if } \frac{h}{w} \geq 1 \end{cases},$$

which, assuming that $h = w$, simplifies to

$$\Omega = f_M \left(m_M + \frac{m_P}{w} \right) + f_P.$$

The probability of marrying for females is derived by analogous reasoning. Assuming that n is large relative to h and w , a focal female marries with probability

$$\Phi = \begin{cases} m_M \left(f_M \cdot 1 + f_P \frac{1}{h} \right) + m_P \left(f_M \cdot 1 + f_P \frac{w}{h} \right) & \text{if } \frac{w}{h} \leq 1 \\ m_M \left(f_M \cdot 1 + f_P \frac{1}{h} \right) + m_P (f_M \cdot 1 + f_P \cdot 1) & \text{if } \frac{w}{h} \geq 1 \end{cases},$$

which, assuming that $h = w$, simplifies to

$$\Phi = m_M \left(f_M + \frac{f_P}{h} \right) + m_P.$$

Inclusive fitness payoffs

We use $\overset{\circ}{\cdot}$ to indicate any attribute that may depend on the relevant strategy for the focal individual, such that its value may differ from the corresponding value for the resident population. For example, $\overset{\circ}{w} \geq 1$ denotes the number of wives for a focal male \mathbb{M} , with $\overset{\circ}{w} \neq w$ for a mutant focal male whose marriage strategy differs from the strategy of resident males, and $\overset{\circ}{w} = w$ in all other cases. With reference to Figure 1 in the text, the inclusive fitness payoff for a focal

male \mathbb{M} can be written as

$$\begin{aligned}
E_{\mathbb{M}} = & \dot{w} \left\{ \left[\underbrace{\Omega \dot{m}_V \left(\delta_m + \dot{w} \frac{\delta_f}{h} \right)}_{\beta_1} + \underbrace{\Omega \dot{w} m_V (h-1) \left(\frac{\delta_m}{w} + \frac{\delta_f}{h} \right)}_{\beta_2} \right. \right. \\
& \left. \left. + \underbrace{\Omega \dot{w} (1-\Omega) \delta_m}_{\beta_3} + \underbrace{\Omega \dot{w} \Omega m_D \left(\delta_m + w \frac{\delta_f}{h} \right)}_{\beta_4} \right] / \dot{w} \right\}^z r_{\mathbb{M}\mathbb{B}'}, \\
& + \left[\underbrace{(1-\Omega) \delta_m}_{\phi_1} + \underbrace{\Omega \dot{m}_D \left(\delta_m + \dot{w} \frac{\delta_f}{h} \right)}_{\phi_2} + \underbrace{(1-\Phi) \delta_f}_{\phi_3} + \underbrace{\Phi h m_V \left(\frac{\delta_m}{w} + \frac{\delta_f}{h} \right)}_{\phi_4} \right]^z r_{\mathbb{M}\mathbb{F}'},
\end{aligned}$$

where β_i represents resources inherited by the offspring \mathbb{B}' of his \dot{w} wives and ϕ_i represents resources inherited by his sister's offspring \mathbb{F}' ; the subscript $i = 1, \dots, 4$ denotes the pathway through which resources are transferred to the heir. $r_{\mathbb{M}\mathbb{B}'}$ and $r_{\mathbb{M}\mathbb{F}'}$ represent the coefficients of relatedness between \mathbb{M} and, respectively, \mathbb{B}' and \mathbb{F}' , as derived below.

β_1 , β_2 , β_3 , and β_4 are only relevant if \mathbb{M} marries, while ϕ_4 is only relevant if \mathbb{F} marries. Specifically:

β_1 represents the resources \mathbb{M} transfers to \mathbb{B}' if his transfer strategy is V; this includes his δ_m and a share $1/h$ of the δ_f of each \mathbb{B} ;

β_2 represents the resources transferred to \mathbb{B}' by the other $h-1$ husbands of each \mathbb{B} , excluding \mathbb{M} , if the transfer strategy of resident males is V; for each husband, this includes a share $1/w$ of his δ_m and a share $1/h$ of \mathbb{B} 's δ_f ;

β_3 represents the resources each \mathbb{C} transfers to \mathbb{B}' if he does not marry;

β_4 represents the resources each \mathbb{C} transfers to \mathbb{B}' if he marries and his transfer strategy is D; this includes his δ_m and a share $1/h$ of the δ_f of each of his w wives;

ϕ_1 represents the resources \mathbb{M} transfers to \mathbb{F}' if he does not marry;

ϕ_2 represents the resources \mathbb{M} transfers to \mathbb{F}' if he marries and his transfer strategy is D; this includes his δ_m and a share $1/h$ of the δ_f of each \mathbb{B} ;

ϕ_3 represents the resources \mathbb{F} transfers to \mathbb{F}' if she does not marry;

ϕ_4 represents the resources each \mathbb{A} transfers to \mathbb{F}' if the transfer strategy of resident males is V; this includes a share $1/w$ of his δ_m and a share $1/h$ of \mathbb{F} 's δ_f .

The inclusive fitness payoff for a focal female \mathbb{F} is derived by analogous reasoning, and can be written as

$$\begin{aligned}
E_{\mathbb{F}} = & w \left\{ \left[\underbrace{\Omega m_V \left(\delta_m + w \frac{\delta_f}{h} \right)}_{\beta_1} + \underbrace{\Omega w m_V (h-1) \left(\frac{\delta_m}{w} + \frac{\delta_f}{h} \right)}_{\beta_2} \right. \right. \\
& \left. \left. + \underbrace{\Omega w (1-\Omega) \delta_m}_{\beta_3} + \underbrace{\Omega w \Omega m_D \left(\delta_m + w \frac{\delta_f}{h} \right)}_{\beta_4} \right] / w \right\}^z r_{\mathbb{F}\mathbb{B}'} \\
& + \left[\underbrace{(1-\Omega) \delta_m}_{\phi_1} + \underbrace{\Omega m_D \left(\delta_m + w \frac{\delta_f}{h} \right)}_{\phi_2} + \underbrace{(1-\Phi) \delta_f}_{\phi_3} + \underbrace{\Phi \mathring{h} \mathring{m}_V \left(\frac{\delta_m}{w} + \frac{\delta_f}{h} \right)}_{\phi_4} \right]^z r_{\mathbb{F}\mathbb{F}'} + \mathring{\alpha},
\end{aligned}$$

where β_i represents resources inherited by the offspring \mathbb{B}' of her brother's w wives and ϕ_i represents resources inherited by her offspring \mathbb{F}' ; as in the previous case, the subscript $i = 1, \dots, 4$ denotes the pathway through which resources are transferred to the heir. $r_{\mathbb{F}\mathbb{B}'}$ and $r_{\mathbb{F}\mathbb{F}'}$ represent the coefficients of relatedness between \mathbb{F} and, respectively, \mathbb{B}' and \mathbb{F}' , as derived below. $\mathring{\alpha} \neq \alpha$ for a mutant focal female whose paternity strategy differs from the strategy of resident females, and $\mathring{\alpha} = \alpha$ in all other cases.

As in the previous case, β_1 , β_2 , β_3 , and β_4 are only relevant if \mathbb{M} marries, while ϕ_4 is only relevant if \mathbb{F} marries. In this case, \mathbb{F} 's husbands transfer vertically with probability \mathring{m}_V because the transfer strategy of males may depend on the marriage and paternity strategies of females (males XS and XI, Table S1). If this is the case, $\mathring{m}_V \neq m_V$ for a mutant focal female whose marriage and/or paternity strategy differs from the strategy of resident females. $\mathring{m}_V = m_V$ in all other cases.

Coefficients of relatedness

For simplicity, we assume that the biological fathers of the offspring of a promiscuous female are not related, and that the h husbands of a polyandrous female are not related and have equal probability of fathering her offspring. Under these assumptions, and assuming that p in the parent generation is equal to p in the previous generation, a female is related to her offspring by $1/2$, a male to his wife's offspring by an average of $p/2h$, and siblings by an average of $(1 + p^2/h)/4$. Thus, $r_{\mathbb{F}\mathbb{F}'} = 1/2$, $r_{\mathbb{F}\mathbb{B}'} = (p/2h)[(1 + p^2/h)/4]$, and $r_{\mathbb{M}\mathbb{F}'} = (1/2)[(1 + p^2/h)/4]$.

$r_{\mathbb{M}\mathbb{B}'}$ must accommodate the fact that the paternity strategy of females may depend on the marriage strategy of males (females XA and XN, Table S1). If this is the case, $\mathring{p} \neq p$ for a

mutant focal male whose marriage strategy differs from the strategy of resident males. $\hat{p} = p$ in all other cases. Because a female’s h husbands have equal probability of fathering her offspring, the coefficient of relatedness between a focal male \mathbb{M} and his wife’s offspring \mathbb{B}' is affected both by the paternity strategy his wife plays against him, and by the paternity strategy she plays against her other $h - 1$ husbands. This can be written as

$$r_{\mathbb{M}\mathbb{B}'} = \frac{(1/h)\hat{p} + [(h-1)/h]p}{2h} = \frac{\hat{p} + (h-1)p}{2h^2},$$

which reduces to $p/2h$ for $\hat{p} = p$.

Stability of social monogamy

The possible combinations of male and female strategies differ in inclusive fitness payoffs; given these payoffs, we can derive evolutionarily stable equilibria consisting of pairs of male and female strategies that cannot be invaded by rare mutants playing alternative strategies (Maynard Smith 1982). The software Mathematica (Wolfram Research, Inc. 2007) was used to perform the numerical analysis and to produce the stability plots.

Only two pairs of pure stable strategies result in social monogamy: (MS, MH) and (MS, MA). Because the model does not yield simple analytical solutions, we describe in detail the analytical results for the simplest case, $p_H = 1$; these are plotted in Figure 2 in the text. Figure S1 shows graphical results obtained with numerical methods for $p_H = 0.5$.

Stability of (MS, MH)

In the first scenario, (MS, MH), resident males are monogamous and suspicious, that is, they transfer vertically if females are monogamous and provide “high” paternity, diagonally otherwise. Resident females are monogamous and always provide “high” paternity. This combination of male and female strategies results in monogamous marriage, vertical transfer, and “high” paternity (Table S1).

(MS, MH) is a weak equilibrium, because resident males MS are neutral with males MV, and resident females MH are neutral with females MA. For $p_H = 1$, males MS are stable for

$$z < \frac{\log 3}{\log 2} \quad \text{against males MD and MI,} \quad (1a)$$

$$w_P \left(\frac{\delta_m}{w_P} + \delta_f \right)^z < 1 \quad \text{against males PV and PS, and} \quad (1b)$$

(a)

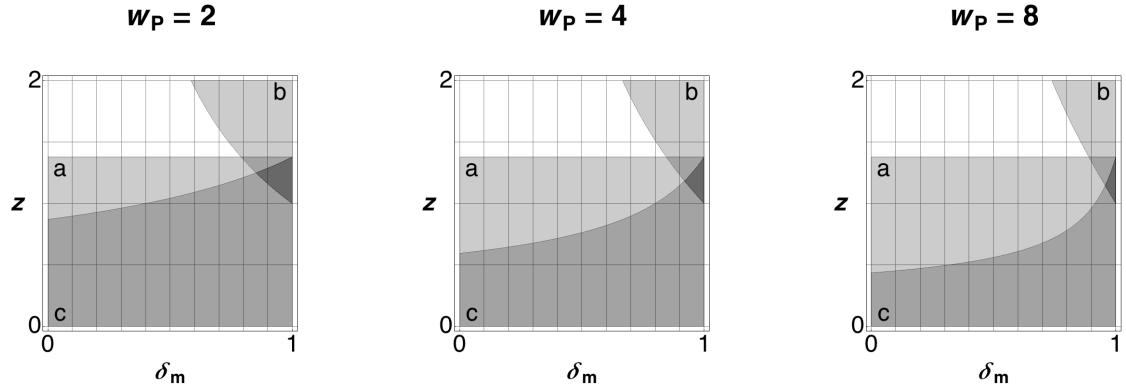

(b)

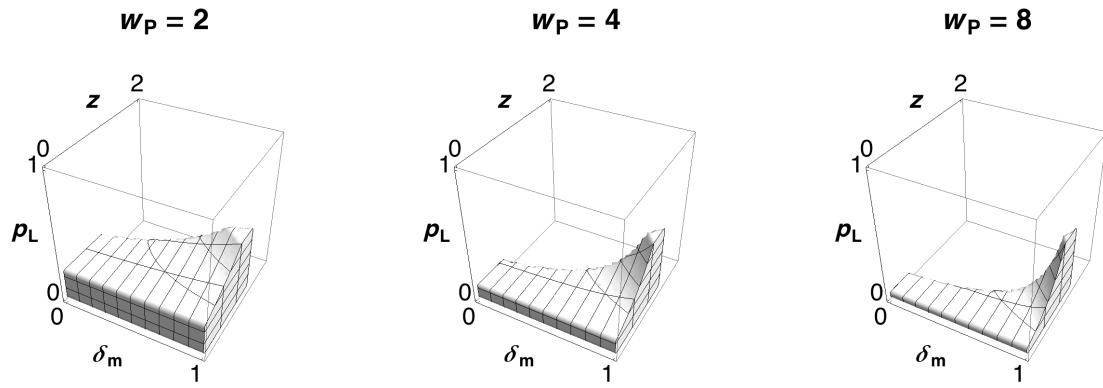

Figure S1: Stability of “suspicious” monogamous males against mutant males with $w_P = 2$, $w_P = 4$, or $w_P = 8$, for $p_H = 0.5$; w_P denotes the number of wives for polygynous males, and p_H the paternity level of males with females who always provide “high” paternity and of monogamous males with “astute” females. δ_m represents the relative male contribution to the resources transferred to the offspring generation; z describes the relationship between resources and individual fitness; p_L represents the paternity level of polygynous males with “astute” females. See text for details. (a), with monogamous females who always provide “high” paternity. **a** is the condition for stability against monogamous males who transfer diagonally, **b** against polygynous males who transfer vertically, **c** against polygynous males who transfer diagonally. Monogamy is stable in the darker area, where all conditions are met. (b), with “astute” monogamous females. Monogamy is stable throughout the volume shown.

$$(2\delta_m + \delta_f + w_P\delta_f)^z < 3 \quad \text{against males PD and PI,} \quad (1c)$$

where $w_P > 1$ denotes the number of wives for a polygynous male.

These conditions are derived by comparing the inclusive fitness payoff for a resident male to the payoff for mutant males. The payoff for a resident focal male \mathbb{M} is given by the resources $\beta_1 = \delta_m + \delta_f = 1$ he transfers to \mathbb{B}' , and by the resources $\phi_4 = \delta_m + \delta_f = 1$ his sister's husband \mathbb{A} transfers to \mathbb{F}' (Figure 1 in the text). Thus, $\delta_{\mathbb{B}'} = \delta_m + \delta_f = 1$ and $\delta_{\mathbb{F}'} = \delta_m + \delta_f = 1$, with inclusive fitness value for \mathbb{M} $(\delta_m + \delta_f)^z(1/2)$ and $(\delta_m + \delta_f)^z(1/4)$, respectively. Because $\delta_{\mathbb{B}'} = 1$ and $\delta_{\mathbb{F}'} = 1$, the inclusive fitness value of these resources is not affected by z (i.e. $\delta_{\mathbb{B}'}^z = 1$ and $\delta_{\mathbb{F}'}^z = 1$).

The payoff for a mutant focal male \mathbb{M} who is monogamous and transfers diagonally (males MD and MI in this population, Table S1) is given by the resources $\phi_1 = \delta_m + \delta_f = 1$ he transfers to \mathbb{F}' , and by the resources $\phi_4 = \delta_m + \delta_f = 1$ male \mathbb{A} transfers to \mathbb{F}' (Figure 1 in the text). Thus, $\delta_{\mathbb{B}'} = 0$, while $\delta_{\mathbb{F}'} = 2\delta_m + 2\delta_f = 2$, with inclusive fitness value for \mathbb{M} $(2\delta_m + 2\delta_f)^z(1/4)$. Note that $\delta_{\mathbb{F}'}^z > 2$ for $z > 1$, that is, values of $z > 1$ result in a greater than twofold increase in fitness for \mathbb{F}' . Condition (1a) specifies that vertical transfer can be advantageous where the benefit to a mutant male of providing extra resources to his sister's offspring is offset by their lower relatedness relative to wife's offspring (i.e. for $z < \log 3 / \log 2$).

The payoff for a mutant focal male \mathbb{M} who is polygynous and transfers vertically (males PV and PS in this population, Table S1) is given by the resources $\beta_1 = (\delta_m + w_P\delta_f)/w_P$ he transfers to each \mathbb{B}' , and by the resources $\phi_4 = \delta_m + \delta_f = 1$ male \mathbb{A} transfers to \mathbb{F}' (Figure 1 in the text). Thus, $\delta_{\mathbb{B}'} = (\delta_m + w_P\delta_f)/w_P$ and $\delta_{\mathbb{F}'} = \delta_m + \delta_f = 1$, with inclusive fitness value for \mathbb{M} $w_P[(\delta_m + w_P\delta_f)/w_P]^z(1/2)$ and $(\delta_m + \delta_f)^z(1/4)$, respectively. Note that $\delta_{\mathbb{B}'} < 1$ if \mathbb{M} contributes at least part of the resources transferred to the next generation (i.e. if $\delta_m > 0$), thus $\delta_{\mathbb{B}'}^z < 1$ for $z > 1$, that is, values of $z > 1$ result in a reduction in the fitness value of the resources. Condition (1b) specifies that monogamous marriage can be advantageous if the fitness value of resources is depleted through division (i.e. for $\delta_m > 0$ if $z > 1$), and becomes increasingly advantageous as each female provides a relatively smaller share of the resources inherited by her offspring (i.e. as δ_m increases and/or w_P decreases).

Finally, the payoff for a mutant focal male \mathbb{M} who is polygynous and transfers diagonally (males PD and PI in this population, Table S1) is given by the resources $\phi_1 = \delta_m + w_P\delta_f \geq 1$ he transfers to \mathbb{F}' , and by the resources $\phi_4 = \delta_m + \delta_f = 1$ male \mathbb{A} transfers to \mathbb{F}' (Figure 1 in

the text). Thus, $\delta_{\mathbb{B}'} = 0$, while $\delta_{\mathbb{F}'} = 2\delta_m + \delta_f(w_P + 1) \geq 2$, with inclusive fitness value for \mathbb{M} $[2\delta_m + \delta_f(w_P + 1)]^z(1/4)$. Note that, as for (1a), $\delta_{\mathbb{F}'}^z > 2$ for $z > 1$, that is, values of $z > 1$ result in a greater than twofold increase in fitness for \mathbb{F}' . Condition (1c) specifies that vertical transfer can be advantageous where the benefit to a mutant male of providing extra resources to his sister's offspring is offset by their lower relatedness relative to wife's offspring; additionally, it becomes increasingly advantageous as each female provides a relatively smaller share of the resources inherited by her offspring (i.e. as δ_m increases and/or w_P decreases). Condition (1c) reduces to (1a) for $\delta_m = 1$.

For $p_H = 1$, the payoff for females MH includes the fitness contribution by their offspring and the fitness contribution by their brother's wife's offspring. Because resident males are suspicious, this is always greater than the payoff for mutant females who are polyandrous and/or provide "low" paternity (females XL, XN, PH, and PA in this population, Table S1), which is limited to the fitness contribution by their brother's wife's offspring (and possibly α_L).

Thus, (MS, MH) is stable for values of δ_m and z for which conditions (1a) to (1c) are satisfied simultaneously (Figure 2a in the text). The upper limit to the range of values of z is given by condition (1c), marked **c** in Figure 2a, and the lower limit by condition (1b), marked **b** in Figure 2a; condition (1a), marked **a** in Figure 2a, is always satisfied where (1c) is satisfied.

Stability of (MS, MA)

In the second scenario, (MS, MA), resident males are monogamous and suspicious, that is, they transfer vertically if females are monogamous and provide "high" paternity, diagonally otherwise. Resident females are monogamous and astute, that is, they provide "high" paternity if males are monogamous, "low" paternity otherwise. As for (MS, MH), this combination of male and female strategies results in monogamous marriage, vertical transfer, and "high" paternity (Table S1).

(MS, MA) is a weak equilibrium, because resident males MS are neutral with males MV, and resident females MA are neutral with females MH. For $p_H = 1$, males MS are stable for

$$z < \frac{\log 3}{\log 2} \quad \text{against males MD and MI,} \quad (2a)$$

$$w_P \left(\frac{\delta_m}{w_P} + \delta_f \right)^z p_L < 1 \quad \text{against males PV and PI, and} \quad (2b)$$

$$(2\delta_m + \delta_f + w_P \delta_f)^z < 3 \quad \text{against males PD and PS,} \quad (2c)$$

As in the previous case, these conditions are derived by comparing the inclusive fitness payoff for a resident male to the payoff for mutant males. The inclusive fitness payoff for a resident focal male \mathbb{M} is identical to the payoff derived for the previous scenario.

Condition (2a) is the condition for the stability of resident males MS against invasion by mutant males who are monogamous and transfer diagonally (males MD and MI in this population, Table S1), and is identical to (1a).

As for (1b), the payoff for a mutant focal male \mathbb{M} who is polygynous and transfers vertically (males PV and PI in this population, Table S1) is given by the resources $\beta_1 = (\delta_m + w_P \delta_f) / w_P$ he transfers to each \mathbb{B}' , and by the resources $\phi_4 = \delta_m + \delta_f = 1$ male \mathbb{A} transfers to \mathbb{F}' (Figure 1 in the text). Thus, $\delta_{\mathbb{B}'} = (\delta_m + w_P \delta_f) / w_P$ and $\delta_{\mathbb{F}'} = \delta_m + \delta_f = 1$; because in this case resident females give polygynous males paternity p_L , these resources have inclusive fitness value for \mathbb{M} $w_P [(\delta_m + w_P \delta_f) / w_P]^z (p_L / 2)$ and $(\delta_m + \delta_f)^z (1/4)$, respectively. As for (1b), $\delta_{\mathbb{B}'} < 1$ if \mathbb{M} contributes at least part of the resources transferred to the next generation (i.e. if $\delta_m > 0$), thus $\delta_{\mathbb{B}'}^z < 1$ for $z > 1$, that is, values of $z > 1$ result in a reduction in the fitness value of the resources. However, because of the reduction in relatedness between polygynous males and their wives' offspring, condition (2b) specifies that monogamy can be advantageous irrespective of whether the fitness value of resources is depleted through division (i.e. for $z > 0$). As for (1b), monogamy becomes increasingly advantageous as each female provides a relatively smaller share of the resources inherited by her offspring (i.e. as δ_m increases and/or w_P decreases). Additionally, monogamy becomes increasingly advantageous as the relatedness between a polygynous male and his wives' offspring decreases (i.e. as p_L decreases); for $p_L < 1/w_P$, any potential fitness benefit to polygyny is offset by the reduction in relatedness to wives' offspring, such that monogamy is stable for all values of δ_m .

Finally, condition (2c) is the condition for stability against mutant males who are polygynous and transfer diagonally (males PD and PS in this population, Table S1), and is identical to (1c).

For $p_H = 1$, the payoff for females MA is always greater than the payoff for mutant females who are polyandrous and/or provide “low” paternity (females XL, XN, PH, and PA in this population, Table S1): as in the previous scenario, the former includes the fitness contribution by own offspring and brother's wife's offspring, while the latter is limited to the fitness contribution by brother's wife's offspring (and possibly α_L).

Thus, (MS, MA) is stable for values of δ_m , z , and p_L for which conditions (2a) to (2c) are

satisfied simultaneously (Figure 2b in the text). The upper limit to the range of values of z is given by condition (2c) and the lower limit by condition (2b); condition (2a) is always satisfied where (2c) is satisfied.

References

- Kokko, H. 1999 Cuckoldry and the stability of biparental care. *Ecol. Lett.* **2**, 247–255.
- Maynard Smith, J. 1982 *Evolution and the theory of games*. Cambridge: Cambridge University Press.
- Reynolds, J. D. 1996 Animal breeding systems. *Trends Ecol. Evol.* **11**, 68–72.
- Wolfram Research, Inc. 2007 Mathematica, *version 6.0*. Champaign, IL.